



CALDAIA  TERMODINAMICA Patented high efficiency  
direct coolant / water exchange to produce  
domestic hot water and heating for small  
and medium-sized users

## HUB RADIATOR MINI



**FIRST START-UP  
MANDATORY FOR  
WARRANTY ACTIVATION**



# MINI HUB RADIATOR heat pump

## Models 6.0 - 8.0 - 11.0 - 16.0

### Technical information

#### SECTION A - GENERAL INFORMATION

Contains all the information relating to the description of air-water heat pumps and their technical characteristics.

#### SECTION B - TECHNICAL NEWS FOR THE INSTALLER

It collects all the information and requirements that the installer must observe for the optimal implementation of the system.

#### SECTION C - USER INSTRUCTIONS FOR USE AND MAINTENANCE

This is the section reserved for the user and contains all the information necessary for proper operation and for periodic checks.

#### Important notes for consultation

- 1 For the purposes of a correct and safe use of the appliance, the installer, the user and the maintenance technician, for their respective skills, are required to observe the indications in this manual.
- 2 The word **ATTENTION** is followed by information which, due to their importance, must be scrupulously observed and whose failure to comply can cause damage to the appliance and / or jeopardize its safety of use.
- 3 Paragraphs highlighted in **bold** contain important information, warnings or advice that you should carefully consider.
- 4 The technical data, aesthetic characteristics, components and accessories shown in this manual are not binding.  
The A2B Accorroni E.G. S.r.l. reserves the right to make any changes deemed necessary for the improvement of your product.
  - References to laws, regulations or technical rules mentioned in this manual are intended for information purposes only and are to be considered valid on the date of printing of the same, shown on the last page. The entry into force of new provisions or changes to those in force will not constitute a reason for any obligation of the A2B Accorroni E.G. S.r.l. towards third parties.
  - The A2B Accorroni E.G. S.r.l. is responsible for the compliance of its product with the laws, directives and construction standards in force at time of marketing. Knowledge and compliance with the laws and regulations relating to design of the systems, installation, operation and maintenance are the sole responsibility, for the respective competences, of the designer, of the installer and user.

### INDEX

1.	MAIN FEATURES .....	4
1.1	Appliance classification .....	4
1.2	Certifications - CE marking .....	4
1.3	Construction features .....	4
1.4	Packaging contents .....	4
1.5	Standard equipment and accessories supplied on request.....	4
1.6	Field of use .....	4
1.7	Safety rules.....	4
2.	U.E. CONNECTIONS / I.U. ....	5
2.1	General provisions .....	5
2.2	Electrical connections U.E.....	5
2.3	R410A refrigerant piping installation .....	5
3.	OUTDOOR UNIT INSTALLATION .....	7
3.1	General indications.....	7
3.2	Distances of respect .....	7
3.3	Roof installation.....	8
3.4	Elimination of air with the vacuum pump .....	8
3.5	Evacuation .....	8
3.6	Opening of the valves and refrigerant release relative to the outdoor unit .....	9
3.7	Pump Down .....	9
3.8	Recovery procedure .....	9
3.9	Acoustic requirements .....	9
4.	INDOOR UNIT INSTALLATION.....	10
4.1	Assembly procedure.....	11
4.2	Dimensions and technical data of outdoor units Booster HUB RADIATOR MINI.....	12
4.3	HUB RADIATOR MINI indoor unit dimensions.....	12
4.4	Dimensions of the internal built-in unit HUB RADIATOR MINI.....	12
4.5	Performance characteristics of the external unit Booster HR 3.0.....	13
4.6	Performance characteristics of the HR Booster outdoor unit 7.8.....	14
4.7	ACS HUB RADIATOR MINI withdrawal table.....	15
4.8	Technical data table HUB RADIATOR MINI.....	15
4.9	Accessories HUB RADIATOR MINI.....	16

5.	<i>DIGITAL CONTROL UNIT</i> .....	17
5.1	Display.....	17
5.2	Icons and displays.....	17
5.3	Key function.....	18
5.4	Access to parameters.....	18
5.5	View and change the set point.....	18
5.6	Main alarms.....	19
5.7	Table of faults causes remedies.....	20
6.	<i>PARAMETER TABLES</i> .....	21
6.1	Sub-menu selection.....	21
6.2	Configuration parameters.....	21
6.3	Digital control unit wiring diagram.....	25
7.	<i>WIRING DIAGRAMS HUB RADIATOR MINI</i> .....	26
7.1	Key to wiring diagrams HUB RADIATOR MINI .....	26
7.2	HUB RADIATOR MINI 6.0 wiring diagram .....	27
7.2	HUB RADIATOR MINI 8.0 wiring diagram.....	28
7.3	HUB RADIATOR MINI 11.0 wiring diagram.....	29
7.4	HUB RADIATOR MINI 16.0 wiring diagram.....	30
8.	<i>HYDRAULIC AND FUNCTIONING DIAGRAMS HUB RADIATOR MINI</i> .....	31
8.1	Hydraulic diagram application example HUB RADIATOR MINI 8.0.....	31
8.2	Hydraulic diagram application example HUB RADIATOR MINI 16.0.....	32
9.	<i>MINI RADIATOR HUB CIRCULATOR</i> .....	33
10.	<i>DIVERTER VALVE HUB RADIATOR MINI</i> .....	33
11.	<i>ELECTRIC RESISTANCE HUB RADIATOR MINI</i> .....	33
12.	<i>WARNINGS</i> .....	33
12.1	Qualification of the installer.....	33
12.2	Preliminary information.....	33
12.3	Transport and handling.....	34
12.4	Using the instructions.....	34
12.5	General system checks.....	34
13.	<i>START-UP</i> .....	34
13.1	First start-up mode.....	34
13.2	Initial start-up checks.....	34
13.3	Put in action.....	34
14.	<i>REPAIR - REPLACEMENT OF COMPONENTS</i> .....	35
14.1	Refrigerant circuit.....	35
14.2	Drying and vacuum of the system.....	35
14.3	Circuit cleaning.....	35
14.4	Refrigerant charge.....	35
14.5	Check for overheating.....	35
15.	<i>DIGITAL WEEKLY TIME PROGRAMMER KIT INSTRUCTIONS</i> .....	36
15.1	Description.....	36
15.2	Operating Instructions.....	36
15.3	Instructions for use - setting the current day and time.....	36
15.4	Programming.....	36
15.5	Manual operation.....	36
16.	<i>CHECKS FOR FIRST START-UP REQUEST HUB RADIATOR MINI</i> .....	37
16.1	Attachments A - B .....	39
17.	<i>FIRST START-UP BOARD PATENTED HUB RADIATOR SYSTEM</i> .....	40
18.	<i>FORM 87 AFTER SALES CLIENT COMPLAINTS</i> .....	44

## **1.MAIN FEATURES**

### **1.1 EQUIPMENT CLASSIFICATION**

The fundamental elements that make up the HUB RADIATOR MINI system are:

- 1) **External moto-evaporator** with defined electronic control as: Split air-water monobloc heat pump”, powered by R410A refrigerant fluid with compressors ON - OFF from 6.22, kW or 8.12 kW.
- 2) **Indoor unit** defined as accumulator radiator a high output closed loop that holds completely separated the technical water from the sanitary water and is made through 2 sequential accumulators with octagonal section, inside which all the exchangers are positioned in copper.

### **1.2 CERTIFICATIONS - CE MARKING**

The patented HUB RADIATOR MINI system complies with directives 97/23 / EC and 98/37 / EEC.

They also comply with the provisions of the following directives: 73/23 / EEC, 89/336 / EEC, as amended by directive 93/68 / EEC.

The internal unit of the HUB RADIATOR MINI system has been designed to be installed only and exclusively inside buildings or on a special external niche that is thermally insulated and protected from atmospheric agents. If this indication is not respected, any type of warranty will be void.

### **1.3 CONSTRUCTION FEATURES**

All the machines are equipped with a microprocessor for controlling and adjusting the operation and safety of the units. Thanks to the patented direct exchange condensers, the products of the HUB RADIATOR MINI series are able to reach high standards of energy efficiency and SCOP.

#### **Other construction features:**

**the cover cabinet** of the outdoor unit is made for all models in sheet metal pre-painted with epoxy powder.

The compressor compartment is completely isolated from the air / refrigerant exchanger compartment; this allows to better protect the electromechanical components;

**the compressor** it is of the high-efficiency rotary type, operating with R 410A refrigerant, mounted on elastic anti-vibration supports, driven by a single-phase electric motor for all models;

**the air / refrigerant gas exchanger** it is made with copper pipes and aluminum fins blocked by mechanical expansion of the pipes, with a high heat exchange surface;

**the fan unit** it consists of a helical fan driven directly by a single-phase asynchronous motor with internal thermal protection.

The fans are equipped with a grille accident prevention protection;

**the quick heat exchanger A.C.S.**, it is made of copper directly immersed in the technical water of the indoor unit with the FIRST IN - FIRST OUT method, so as to eliminate the problem of legionella.

**the refrigeration circuit** and the connections between the individual components are made in copper tube specific for refrigeration. The lamination member, the cycle inversion valve and the liquid separator are part of the refrigeration circuit;

**the electrical panel** command and control is directly positioned inside the cover cabinet, above the expansion tank.

**the control system** microprocessor with keyboard is located on the control plate accessible directly on the front of the cover cabinet, and can be remotely operated using the appropriate remote control and command panel, available as an accessory, to be installed on the wall or recessed.

the indoor unit is supplied complete with all the appropriate internal copper exchangers, auxiliary back-up and emergency supplementary resistor, refrigerant gas connections, DHW, air siphon jolly valve, safety valve, filling cock, pressure gauge, diverter valve to give priority to the sanitary, flow switch, electronic circulator, expansion tank, temperature probes.

### **1.4 CONTENT OF THE PACKAGING**

The device is shipped on wooden pallets, with extruded expanded polystyrene protections and wrapped in a layer of plastic fabric with air bubbles.

The identification data of the device are shown both on the label on the packaging and on the technical data plate applied inside the cover cabinet.

**Do not remove the technical data plate for any reason**, since the references contained therein are necessary for any maintenance interventions.

**Inside the packaging there is also an envelope containing this manual and the warranty certificate, which must be delivered to the owner of the device so that he can keep them carefully for any future use or for consultation.**

### **1.5 STANDARD EQUIPMENT AND ACCESSORIES SUPPLIED ON REQUEST**

The wide range of standard equipment and accessories available on request allow optimal exploitation of all the functions of the machines and system to which they are served.

### **1.6 FIELD OF USE**

The appliances designed and manufactured for heating water in hydronic air conditioning systems and to produce DHW must be used only for this purpose, in relation to their technical specifications and performance.

The quality and dimensions of the materials used guarantee a good life span and are suitable for the operation of the devices both as a whole and in their individual components, subject to an installation carried out in a workmanlike manner and under conditions of mechanical stress, chemical and thermal corresponding to a suitable use.

**ATTENTION! All uses not expressly indicated in this manual are considered improper and are not permitted; in particular, the use of the equipment in industrial processes and / or installation in environments with a corrosive or explosive atmosphere is not envisaged.**

**The manufacturer declines any liability for damage to persons, animals or property resulting from non-compliance with the instructions in this manual, from modifications or tampering with the product, from installation, adjustment, maintenance errors and from improper use.**

Failure to comply with the instructions in this manual will also result in forfeiture of the warranty conditions.

### **1.7 SAFETY RULES**

**ATTENTION! Installation and maintenance must be carried out exclusively by specialized and specially authorized personnel.**

**The connection to the power supply must be performed in accordance with current national plant standards.**

**During installation and maintenance operations, it is always necessary to operate in conditions of maximum safety, follow the instructions given in this manual and any warning labels applied to the product.**

**Respect the installation and operating limits indicated in this manual, never modify the internal electrical wiring and refrigeration pipes, do not modify or disable the safety and regulation devices.**

**Before any inspection, maintenance, or anything else involving access to the internal parts of the appliance, disconnect the general power supply.**

In case of need or clarification for installation and maintenance, contact a Technical Assistance Center authorized by A2B ACORRONI E.G.

**Table 1 - HUB RADIATOR MINI cable specifications**

Models	Connection cable QE power supply indoor unit	Connection cable QE power supply indoor unit	Cable C-1-2	Cable Pb3	Switch thermal magneto
	Section	Section	Section	Section	Section
6.0	4.0 mm <sup>2</sup> x 3	4.0 mm <sup>2</sup> x 3	1,50 mm <sup>2</sup> x 3	0,75 mm <sup>2</sup> x 4	20 A curv. D
8.0	4.0 mm <sup>2</sup> x 3	4.0 mm <sup>2</sup> x 3	1,50 mm <sup>2</sup> x 3	0,75 mm <sup>2</sup> x 4	32 A curv. D
11.0	6.0 mm <sup>2</sup> x 3	4.0 mm <sup>2</sup> x 3	1,50 mm <sup>2</sup> x 3	0,75 mm <sup>2</sup> x 4	40 A curv. D
16.0	6.0 mm <sup>2</sup> x 3	4.0 mm <sup>2</sup> x 3	1,50 mm <sup>2</sup> x 3	0,75 mm <sup>2</sup> x 4	40 A curv. D

**2. CONNECTIONS U.E. / U.I.**

**2.1 GENERAL PROVISIONS**

- 1) The HUB RADIATOR MINI system is designed to work exclusively with the indoor unit positioned inside of the building to be heated and the booster outside.
- 2) During the installation phase it must be carefully checked that the distance and the difference in height between the 2 units comply with data reported in this manual (Table 4).
- 3) Before installation, check that the wall is where you are chosen to position the internal accumulation to be able to withstand the weight of the accumulation itself and of the water contained in it.
- 4) In case of replacement of an existing generator carry out the cleaning the system and adding a special anti-algae additive.
- 5) When you choose to install the system HUB RADIATOR MINI, there is to be taken into consideration the electrical absorption of the outdoor unit. Then arrange all the necessary works to adapt the electrical system (meter, cable section, switches circuit breakers, etc.) to ensure correct operation and a constant voltage between 220V and 240V in correspondence with the power cables of the outdoor unit. With voltage below 220V it is mandatory to install one voltage stabilizer able to guarantee, the voltages allowed above, otherwise all types will be void warranty.

**2.2 ELECTRICAL CONNECTIONS U.E.**

Connect the cable to the electrical panel:

- 1) The connection cable of the indoor and outdoor unit must be of type H07RN-F.
- 2) Lift the electrical box panel and remove the screws, then remove the cover.
- 3) Connect the cables according to the markings. Connect the cable to the outdoor unit:
- 4) Remove the cover of the outdoor unit.
- 5) Connect the terminal cables according to the numbers on the unit terminal block, respecting the sections shown in table 1
- 6) Secure the cables so that they do not come into contact with parts electric or metal.

**2.3 INSTALLING THE PIPES FOR THE REFRIGERANT R410A**

The main cause of refrigerant gas leaks is due to a defect in the flare. Carry out the folders correctly, respecting the following indications:

**A) Cut the pipes and the cable (Fig. 1)**

- Use pipes with suitable measures for the installed unit (Table 2).
- Measure the distance between the indoor and outdoor unit.
- Cut the pipes to a length slightly greater than distance measured.
- Cut the 1.5 m electric cable. longer than the length of the tube

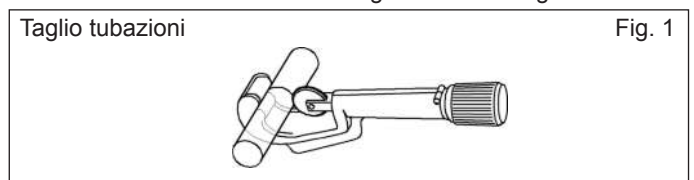

**Table 2 - Diameter of R410A refrigerant connections**

Model	Ø LIQUID	Ø GAS
6.0	1/4" - 1/4"	3/8" - 3/8"
8.0	1/4"	5/8"
11.0	1/4" - 1/4"	3/8" - 5/8"
16.0	1/4" - 1/4"	5/8" - 5/8"

**B) Removal of the burr (Fig. 2)**

- Completely remove all burrs from the section cross section of the tube.
- The processing must be performed with the end of the tube down so that burrs do not fall into the tube.



**C) Flaring (Fig. 3)**

Remove the nuts fixed on the indoor and outdoor unit, insert them on the pipe and perform the flaring and removal of the burrs, as previously indicated.

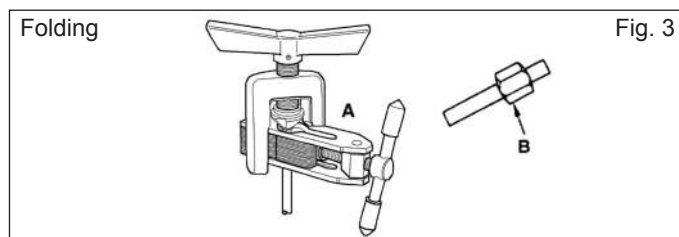

**D) Fixing the refrigeration pipes (Fig. 4)**

Align the pipes by lubricating the external surface of the pipes in correspondence with the flare. Sufficiently tighten the nut using two wrenches.

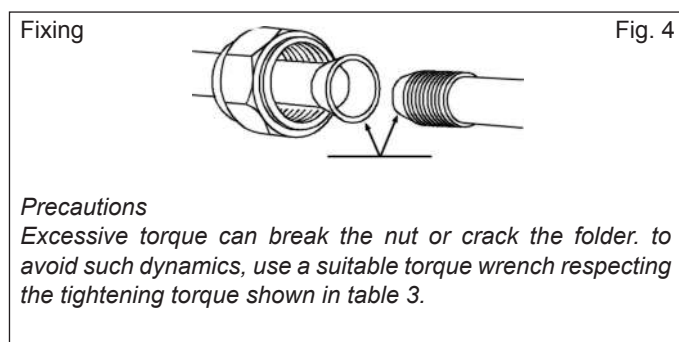
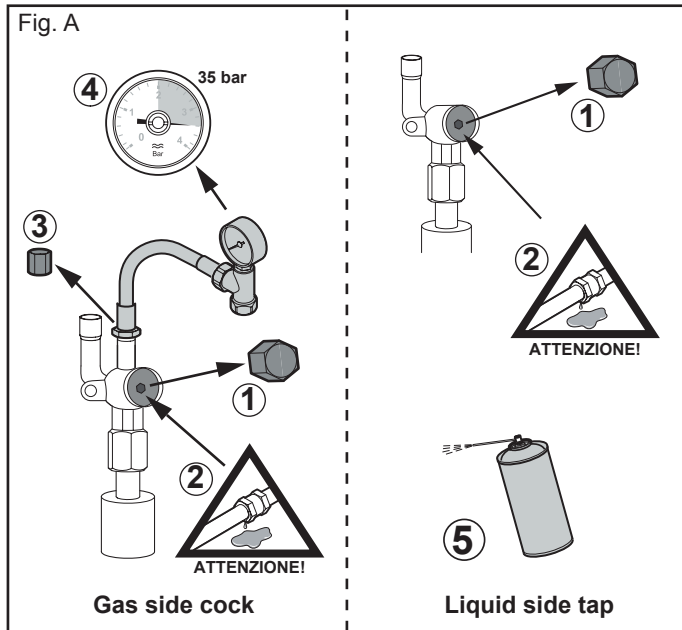

**Table 3 - Tightening torque**

Diameter	Tightening torque (N/m)
Ø 3/8	42
Ø 5/8	65
Ø 1/4	18

**E) Checking the tightness of the refrigeration lines (Fig. 5)**

- 1) Open the caps of the sectioning valves (Fig. A n. 1).
- 2) Check that the section valves are closed (Fig. A n. 2).
- 3) Remove the plug from the service connection on the valve sectioning (Fig. A n. 3).
- 4) Connect the pressure gauge and the nitrogen bottle to the valve stop then gradually increase the pressure in the pipes of the refrigerant connection and in the internal module at 35 bar, in 5 bar increments (Fig. A n. 4).
- 5) Check the tightness of the fittings with a detector spray escapes. If there are leaks, repeat the operations in the order indicated and check the seal again (Fig. A n. 5).
- 6) Leave the circuit under nitrogen pressure for at least 24 hours e check that at the end of this time the pressure initial does not go down.
- 7) Release the pressure and nitrogen.



**(Example A) INSTALLATION WITHIN 5 METERS**

Example of installation without additional gas refill R410a refrigerant, distance 4 meters.

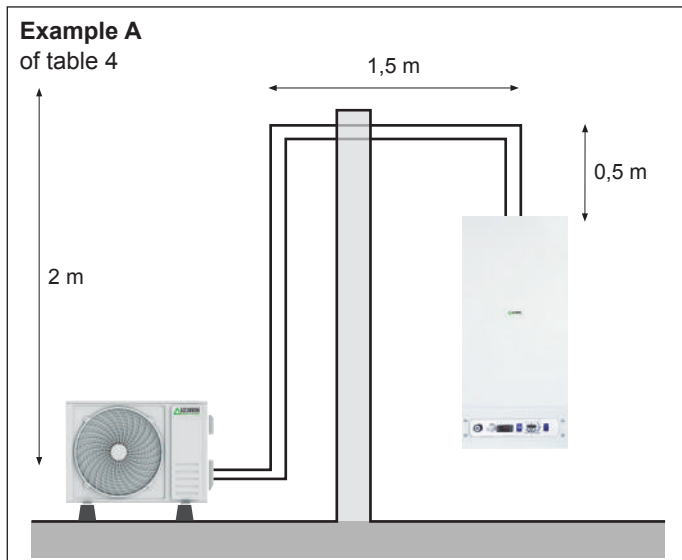

**(Example B) INSTALLATION WITH MINIMUM PERMISSIBLE LENGTH**

If the distance between the Indoor Unit and Outdoor Unit is less than 3 meters (as in this case where the length of the pipes does not exceed 2 meters), the pipes must be cut at 3 meters and roll up the final part in correspondence with the outdoor unit.

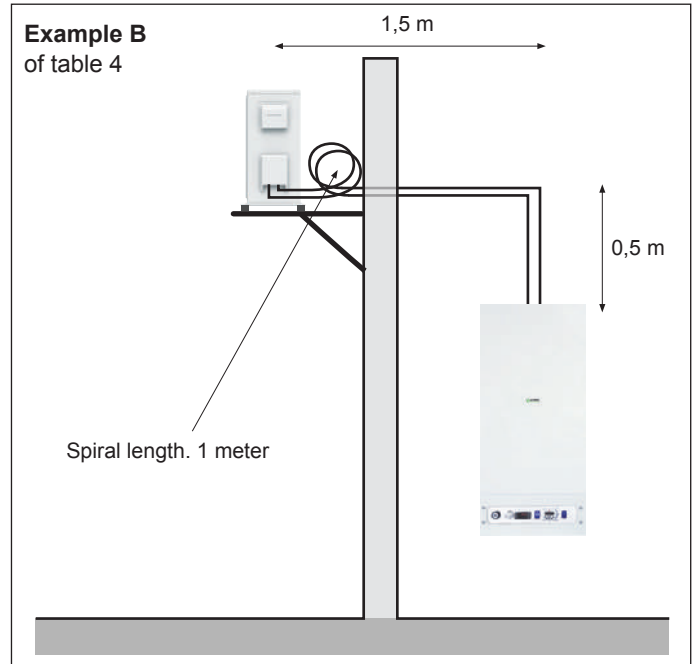

**(Example C - D - E)**

**(C) MAXIMUM PIPE LENGTH** (refrigerant gas)

**(D) MAXIMUM DIFFERENCE IN HEIGHT** (between U.E and U.I.)

**(E) ADDITIONAL REFRIGERANT AMOUNT** (over 5 m)

In this configuration, the effective length of the pipes is 6 m horizontally and 4 m vertically, in total 10 m.

We will then add 100 grams of R410a refrigerant gas or 5 m x 20 g / m = 100 grams.

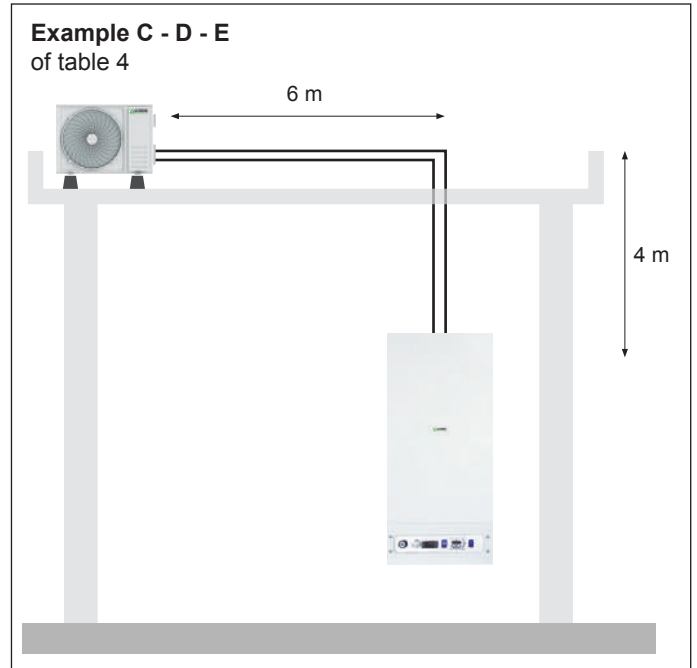

**Table 4 - Admissible distances U.I. - E.U.**

Models	HR 3.0	HR 7.8
<b>A</b> Maximum length allowed without adding refrigerant	5*m	5*m
<b>B</b> Minimum allowed length of refrigerant gas	3*m	3*m
<b>C</b> Maximum length of refrigerant gas piping	15*m	15*m
<b>D</b> Maximum admissible height difference between U.E and U.I.	5*m	5*m
<b>E</b> Additional refrigerant quantity over 5 meters	20*g/m	20*g/m

Failure to comply with this application **will result in the non-ignition by the authorized assistance**

## ATTENTION!

In fig. 5 shows an example of an inadmissible application, with a distance of 10 meters but with a difference in height of > 5 meters.

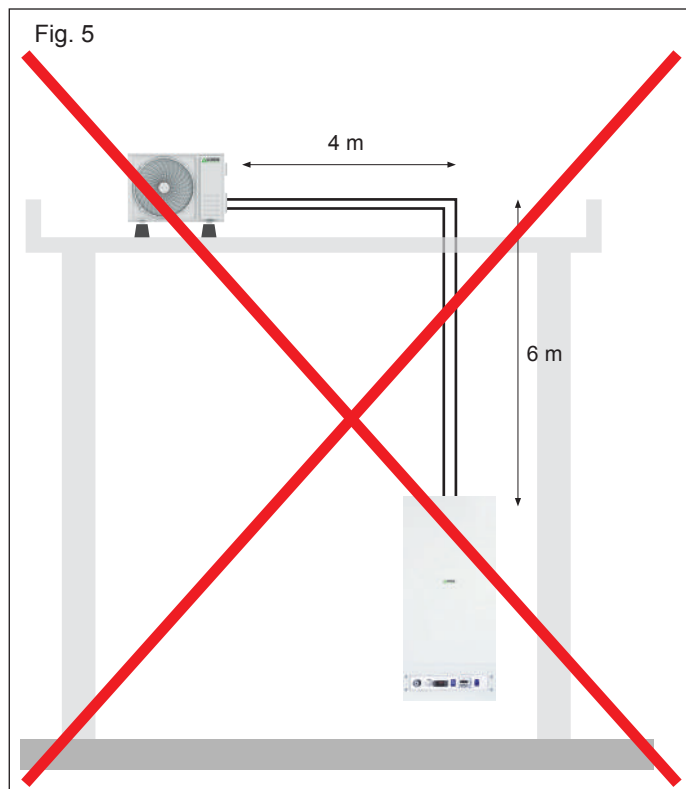

### 3. OUTDOOR UNIT INSTALLATION

#### 3.1 GENERAL INDICATIONS

When choosing the installation position, carefully observe the following indications:

- Make sure that the difference in height between the INDOOR UNIT and the UNIT OUTSIDE is not greater than 5.0 m.
- The appliance must be installed so that the influences of adjacent structures and / or the effects of climatic conditions details (snow, wind etc ...), do not compromise the operation of the product and / or the safety of people and property.
- Make sure that the space in the back of the unit is greater than 30 cm. The front must have more than 60 cm. of space.
- Make sure there are no obstacles to free movement of the air through the heat exchangers:

A) do not place plants or animals directly next to the flow of the air;

B) avoid installation in corners where it usually settles of dust, leaves and anything else that can reduce efficiency of the exchangers obstructing the passage of air (Fig 6).

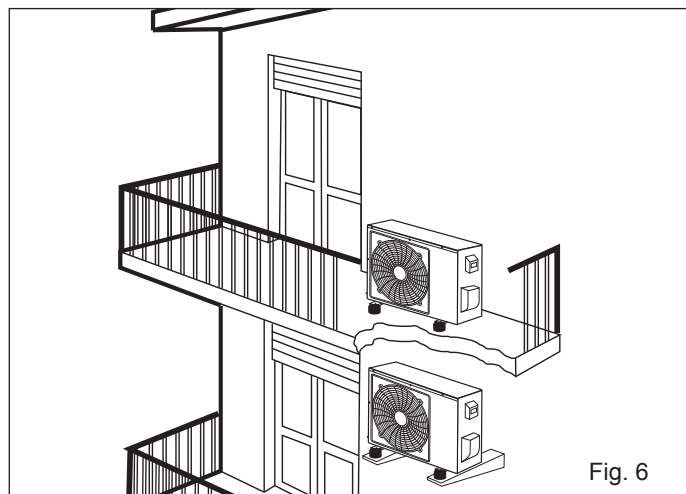

- Avoid installation in bottlenecks and small shafts as acoustic reverberations could be favored.

Inquire about any limits in noise emissions provided for the area of the municipal territory in which it is installed the appliance. In case of doubts it is advisable to consult previously an acoustic technician, qualified for one impact assessment, in order to prevent disputes from third party.

- Prevent the air expelled from the fans from penetrating through adjacent doors and / or windows, causing situations disturbing people.
- Install the outdoor unit on a rigid base equipped with appropriate anti-vibration bearings to avoid the increase of vibrations e noise, so as not to disturb neighbors (Fig. 7).

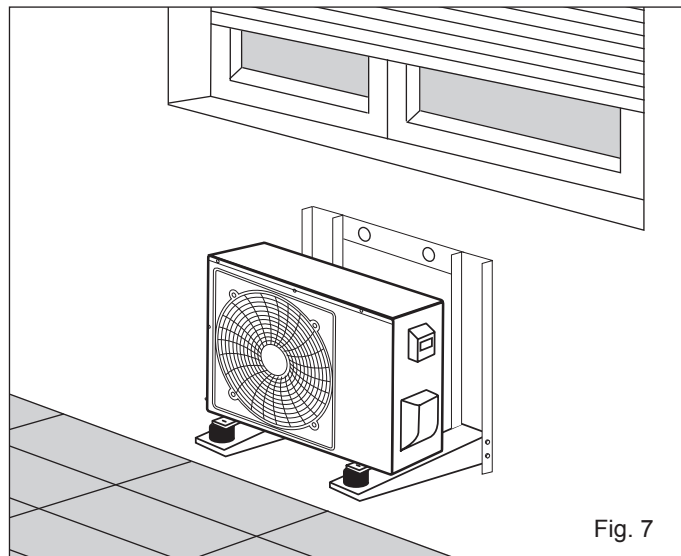

- Position the air outlet so that the flow is not hindered in any way. In case of strong wind, make sure that the fan is working properly by positioning the unit longitudinally, along a wall or using a shield.
- If the appliance is to be suspended from an external wall, the substrate must comply with the technical specifications. The wall where the unit must be installed, it must be brick or material of similar consistency, otherwise it must be Reinforced. The support brackets must be stable, resistant and with an adequate degree of protection against corrosion.

**ATTENTION!** Make sure of the load-bearing capacity of the part on which the shelves are placed and of the anchoring system to the wall itself, according to the weight of the appliance to be installed.

- Do not install the appliance near heat sources and / or fire risk areas.
- Installation in areas with a highly corrosive atmosphere not is allowed; in particular climatic conditions such as in proximity of the sea, it is mandatory to provide a duration of shorter life of the product and in any case a more frequent one ed careful maintenance.
- In the outdoor unit, from which the water of condensation, provide a suitable drainage and / or channeling of the same, in order to avoid situations of danger due for example to the formation of ice on transit areas.
- The outdoor unit is designed to be installed outdoors and it does not need a special base, however it must be positioned safely on a support surface horizontal with adequate load bearing capacity and equipped with suitable anti-vibration rubber pads.

#### 3.2 CLEARANCE DISTANCES OUTDOOR UNIT (Fig. 8)

Respect the minimum spaces, so as to allow correct operation and all installation and maintenance operations.

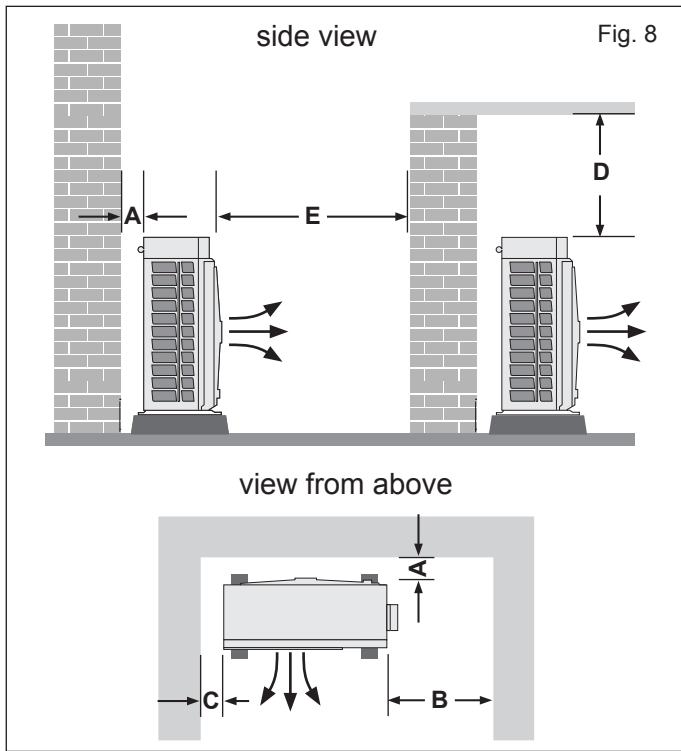

LEGEND:

(A = 15 cm) (B = 50 cm) (C = 15 cm)  
(D = 60 cm) (E = 100 cm)

### 3.3 ROOF INSTALLATION (Fig. 9)

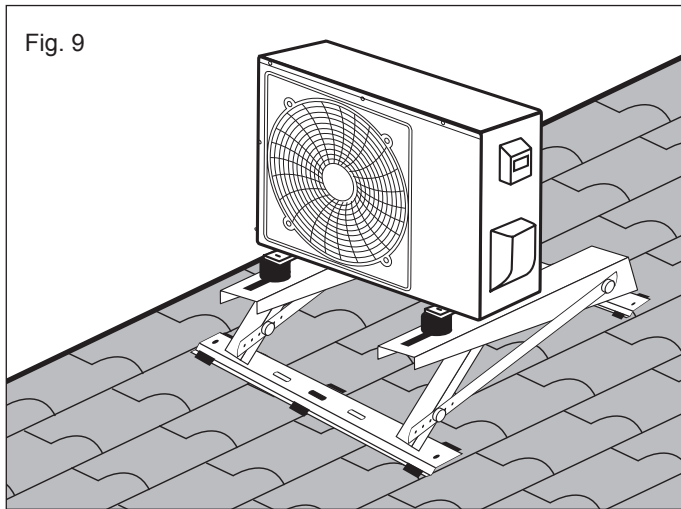

- If the outdoor unit is installed on a roof, be sure to level the unit. Make sure the roof structure is appropriate for mounting of the unit.
- For mounting on a sloping roof it is recommended to use the appropriate shelf shown below (see Chap. 4.9 ACCESSORIES HUB RADIATOR MINI)



**ANCHORING BRACKET FOR INCLINED ROOF FOR EXTERNAL BOOSTERS MOD. HR 3.0 - 7.8 - 9.0 RUBBER ANTI-VIBRATION SYSTEMS INCLUDED**

- If the outdoor unit is installed on the roof or external walls, this could cause excessive noise and vibration and be classified as an unsuitable installation for the service.

### 3.4 ELIMINATION OF AIR WITH THE VACUUM PUMP (Fig 10)

The air and humidity in the refrigeration system can cause undesirable effects as indicated below:

- Increased pressure in the system.
- Increase in absorbed current.
- Decrease in the efficiency of the refrigerant.
- Freezing and obstruction of the capillary pipes.
- Corrosion of parts of the refrigeration system.

In order to avoid the above, the indoor assembly and pipes, placed between the indoor and outdoor assemblies, must be tested for leaks and purged to remove non-condensing elements and moisture from the system. Check that each pipe (both the gas and liquid side pipes) between the internal and external groups has been connected correctly and that all the wiring required for testing has been carried out.

- Remove the valve cap on the outdoor assembly.
- Make sure that at this point both the gas valves and the liquid remain closed.
- Check the length of the hose and the relative amount of refrigerant, for correct charging, check the superheat value.

When changing the location of the unit, bleed with the vacuum pump.

Make sure that the refrigerant inside the air conditioner is always in a liquid state.

The outdoor unit is supplied with a charge of R410A refrigerant gas suitable for ensuring proper operation up to a maximum distance of 5 meters from the indoor unit.

If you decide to install the 2 units at a distance greater than 5 meters, be sure to add 20 g of refrigerant gas for each additional meter of piping (table 4).

For example, if there are 7 meters of piping between the outdoor and indoor units, add 40 g of R410A gas.

**In any case, never exceed 15 meters.**

Add only after vacuuming the pipes connecting the 2 units, after which you can proceed with opening the gas taps, mounted on the machine.

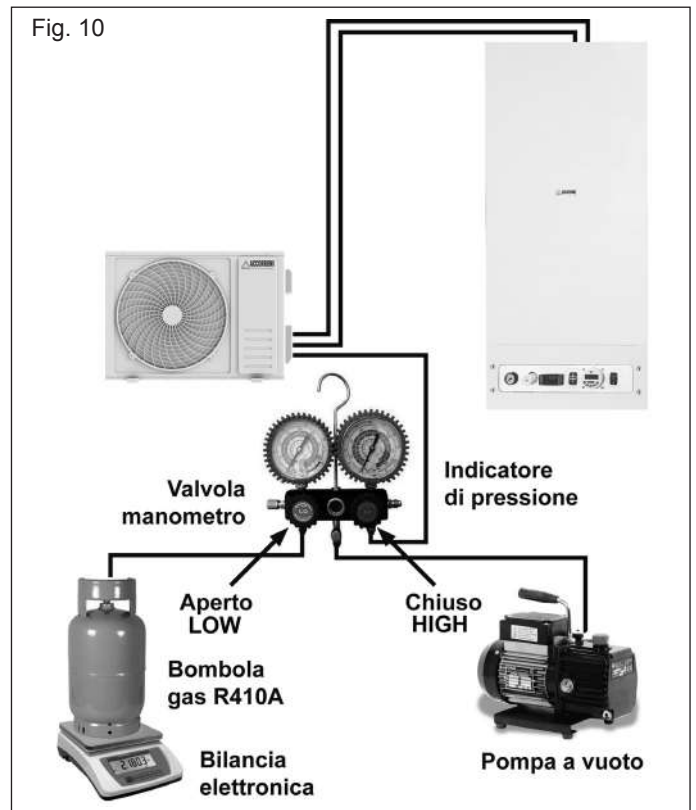

### 3.5 EVACUATION

Connect the end of the charging hose to the vacuum pump to evacuate the air from the pipes of the indoor unit. Check that the "LOW" knob of the pressure gauge valve is open.



Then run the vacuum pump.  
 The running time varies depending on the length of the pipes and the capacity of the pump.  
 When the desired vacuum is reached, close the "LOW" knob of the pressure gauge valve and stop the vacuum pump.  
 Finally, using a service valve wrench, turn the gas side valve stem counterclockwise to fully open.  
 Loosen the charging hose connected to the gas side service port to relieve the pressure, then remove the hose.  
 Replace the gas valve and service plug cover nut and tighten securely with an adjustable wrench.  
 This procedure is very important to avoid system leaks.  
 Replace the service valve caps on both the gas and liquid side and tighten well. This completes the air purge procedure with the vacuum pump, make sure that all pipes are connected correctly and that the service valves on the gas and liquid sides are completely open.

### 3.6 OPENING THE VALVES AND RELEASING THE REFRIGERANT RELATING TO THE OUTDOOR UNIT

- 1) Remove the cap of the liquid sectioning valve coolant, liquid side (Fig. B n. 1).
- 2) Open valve A with the aid of a hex wrench turning anticlockwise until it stops (Fig. B n. 2).
- 3) Replace the cap.
- 4) Remove the cap from the gas cut-off valve coolant (Fig. B n. 4).
- 5) Open the valve with pliers by turning counterclockwise of a quarter of a turn (Fig. B n. 5).
- 6) Replace the cap.
- 7) Disconnect the vacuum gauge and the vacuum pump.
- 8) Put the cap back on the valve (Fig. B n. 3).
- 9) Tighten all the caps with the aid of a torque wrench with tightening torque from 20 to 25 N / m. See table 3.
- 10) Check the tightness of the fittings using a leak detector.

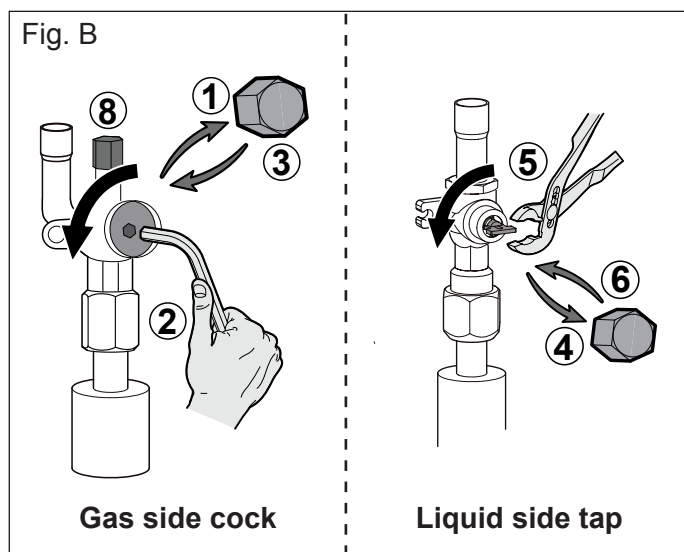

### 3.7 PUMP DOWN

This procedure is carried out when the unit needs to be moved or assistance is carried out on the refrigerant circuit.  
 Emptying allows all the refrigerant to be collected in the outdoor unit without leaks.

### 3.8 RECOVERY PROCEDURE

- Connect a low pressure gauge with a hose to the gas valve service socket.
- Half open the gas valve and empty the air from the pipeline pressure gauge using refrigerant gas.
- Close the liquid valve completely.
- Turn on the machine in cooling mode.
- When the pressure of the manometer goes between 0 and 0.5 kg / cm 2G (between 14.2 and 7.1 P.S.G.I) close the valve completely gas and quickly turn off the indoor unit.

Complete recovery of the refrigerant from the outdoor unit was thus carried out.

**ATTENTION! Be sure to perform the emptying procedure with the unit in COLD MODE.**

### 3.9 ACOUSTIC REQUIREMENTS (Fig. 11)

During the installation phase of a HUB RADIATOR MINI heat pump, it is necessary to evaluate very carefully where the outdoor unit is positioned, in order to avoid induced noise that goes beyond the tolerance threshold.

Fig. 11

### POSITIONING OF THE OUTDOOR UNIT

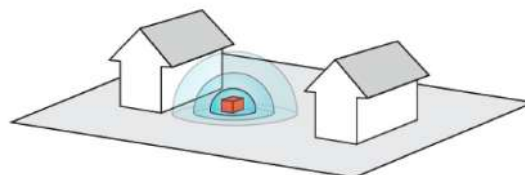

on the ground, free installation + 3 dB (A)

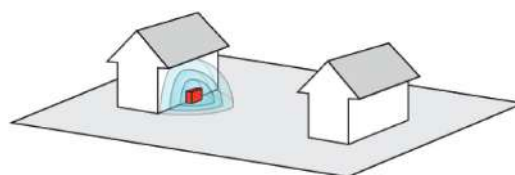

against the facade + 6 dB (A)

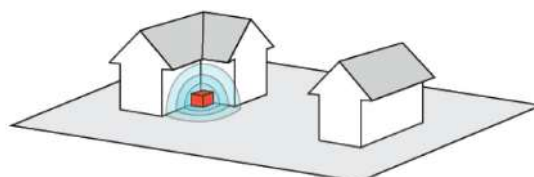

in a corner of the recessed facade + 9 dB (A)

The external evaporating motor unit during work generates external noise emissions and requires appropriate measures to reduce the incidence of noise produced by the compressor and / or fan.  
 Very important then is the system execution that is combined with the heat pump in this regard it is recommended to use the following accessories listed below (see Chapter 4.9 ACCESSORIES HUB RADIATOR MINI)



**ANTI-VIBRATION FLOOR BASE IN VULCANIZED RUBBER (HEIGHT FROM THE GROUND MM 95) WITH LEVEL AND SCREWS FOR BOOSTER HR 3.0 - 7.8 - 9.0**



**KIT ANTIVIBRANTI PER INSTALLAZIONE SU MENSOLE**

#### 4. INDOOR UNIT INSTALLATION

Always install the accumulation inside the building to heat away from atmospheric agents and inside a room at a controlled temperature.

Make sure that the wall on which the indoor unit will be installed is able to support the entire operating weight of the system.

Below are the main components that make up the indoor unit.

##### Main components

- 1 8 liter expansion vessel
- 2 Electrical panel
- 3 WILO YONOS PARA RS 25/6 circulator
- 4 Domestic hot water delivery
- 5 Drain cock "
- 6 Heating system flow 3/4 "

- 7 Safety valve with 3 bar calibration
- 8 1/2 "domestic cold water inlet
- 9 Diverter valve with 1 "connections
- 10 System return 3/4 "
- 11 3/8 "jolly air vent valve
- 12 Refrigeration connections for external booster / s
- 13 Manual filling tap
- 14 Daily weekly programmer
- 15 Wall fixing bracket
- 16 System pressure gauge
- 17 Integrative electric heater of 1,5 kW
- 18 Digital electronic control unit
- 19 Electric heater ON OFF button
- 20 70 liter technical inertial storage tank
- 21 Indoor unit cover
- 22 Emergency key / electric heater integration

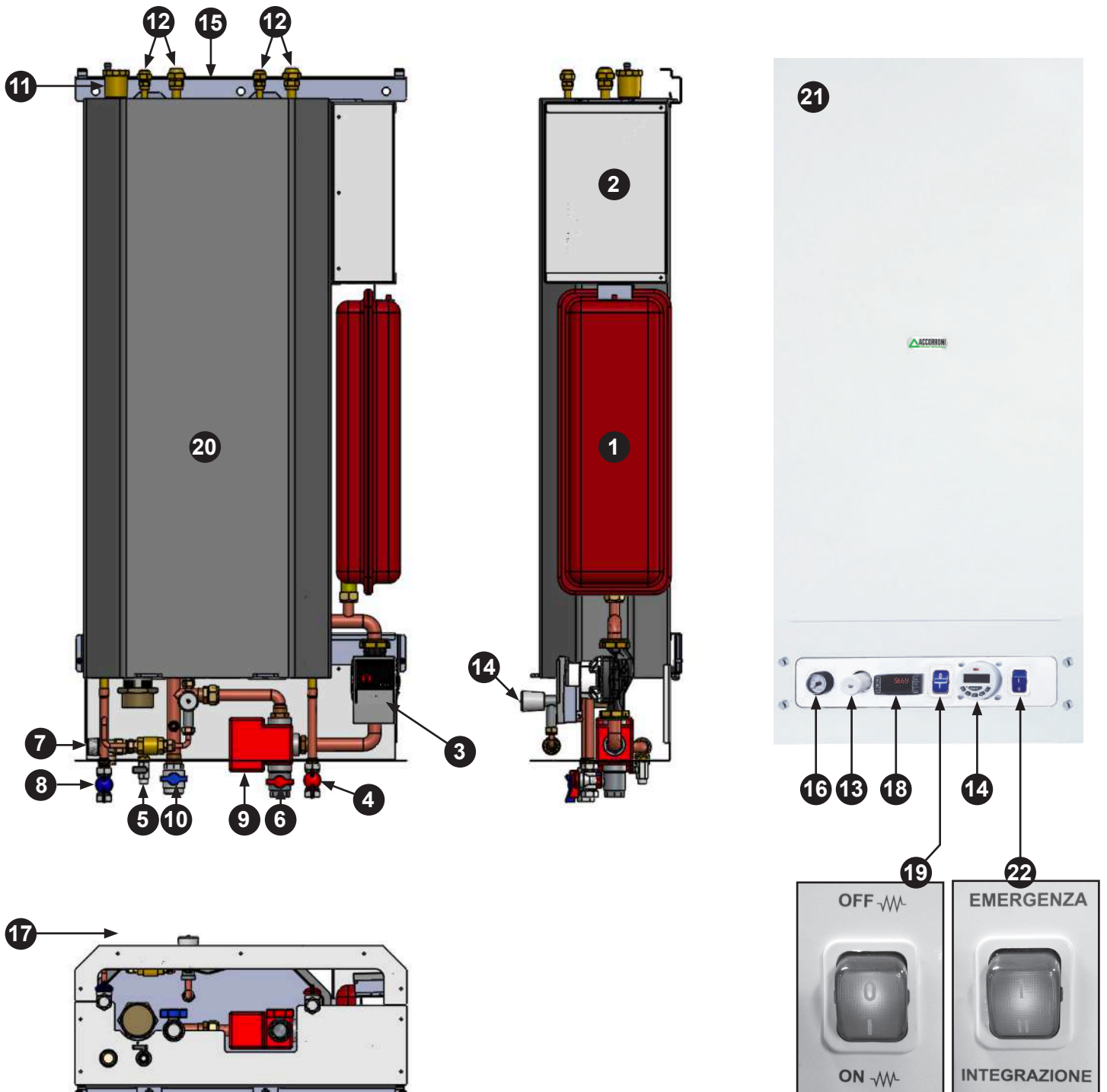

#### 4.1 ASSEMBLY PROCEDURE

**A)** Place the wall fixing bracket on the wall where you want to install the indoor unit.

Using a level, make sure that the bracket is perfectly horizontal and that the support surface is regular.

Use the bracket as a template and mark the position of the holes to be made.

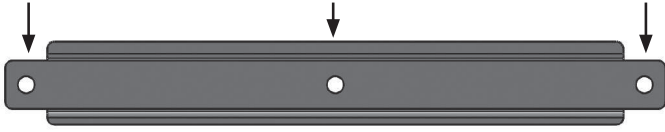

**B)** Once the position of the fixings has been marked, make appropriate holes for inserting the wall plugs to be chosen based on the weight of the indoor unit in operation and the structural type of the wall.

**C)** Insert the fixing bracket again and tighten with the wall screws, chosen on the basis of the indications given in point B.

**D)** Hang the internal unit of the bracket just fixed to the wall without a cover cabinet using the slots located on the lower part of the bracket.

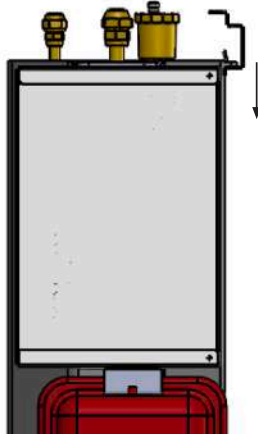

**E)** Once the indoor unit has been hung on the wall fixing bracket, proceed with the connection of the 1/2 "sanitary circuit

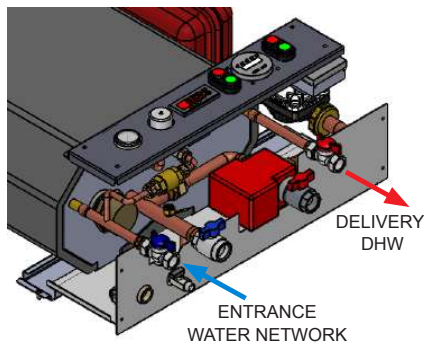

**F)** Proceed with connecting the flow and return of the heating system using the 3/4 "connections

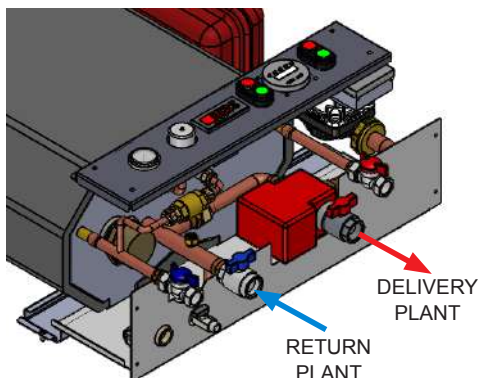

**ATTENTION!** the circulator mounted on the machine is able to provide the nominal water flow rate with the head indicated in the technical data table. Check that the pressure drops are not higher than the available available head.

However, it is recommended to comply with the following requirements:

- the diameter of the pipe of the withdrawal line from the network must not never be less than that of the attachment of the machine;
- adequately fix the pipes, the weight of which must not burden the device;
- properly insulate the piping in order to achieve it the dispersion of heat.

**G)** Connect a special safety drain at the 1/2 "female threaded connection of the s safety valve.

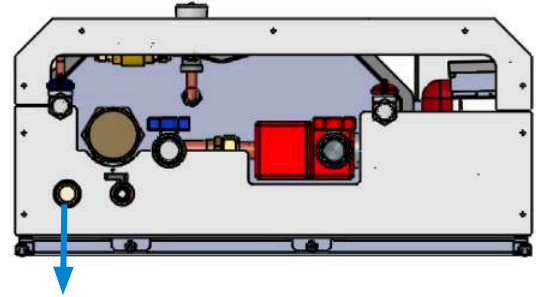

SAFETY VALVE DISCHARGE

**H)** Make the electrical connections between the electrical panel and the main power supply and between the electrical panel and the terminal block located on the right side of the outdoor unit following the instructions in table 1.

Arrange a dedicated power line that starts directly from the meter to bring the main power supply to the electrical panel located inside the cover of the indoor unit.

This line must be equipped with a special magneto-thermal protection placed upstream and must be of such a section as to avoid a voltage drop higher than 2.5 V.

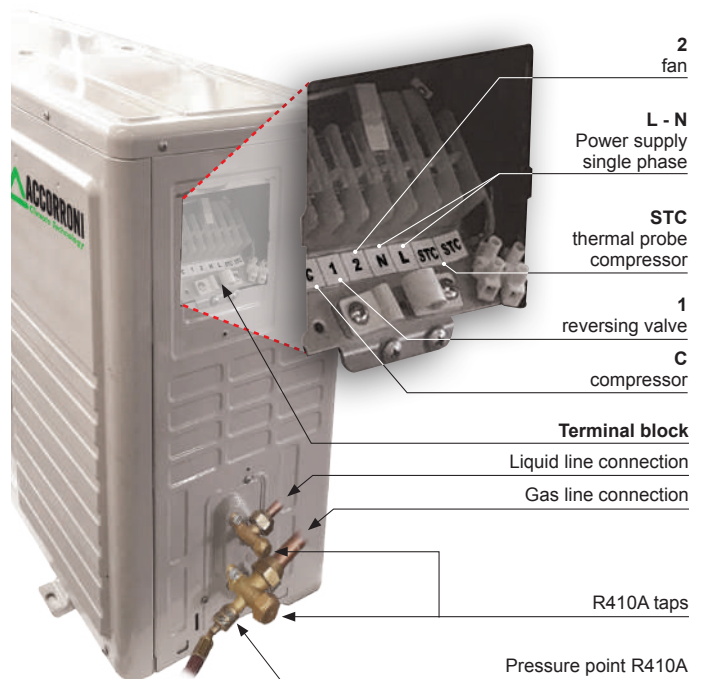

**ATTENTION!** all electrical connections must be carried out by qualified personnel and the electrical system must comply with all applicable regulations.

**I)** Proceed with the refrigerator connections following all the instructions given in section 2.3 of this manual.

When shaping the pipes, avoid any type of crushing and make sure that each portion of the pipe is perfectly thermally insulated from start to finish.

**ATTENTION!** compliant with all current regulations.

All refrigeration connections must be carried out by qualified personnel in possession of the F-GAS certification (DPR January 27, 2012, n.43)

L) Once all the connections have been made, request the indoor unit with the special cover cabinet which must first be placed from top to bottom on the wall fixing bracket and then rotated towards the wall until it hooks onto the special retractable pins. , placed on the lower fixing plate.

M) Before filling the system, make sure that all the pipes are well connected and that there are no leaks, proceed with opening the filling tap, vent all the air present in the system and put under pressure.

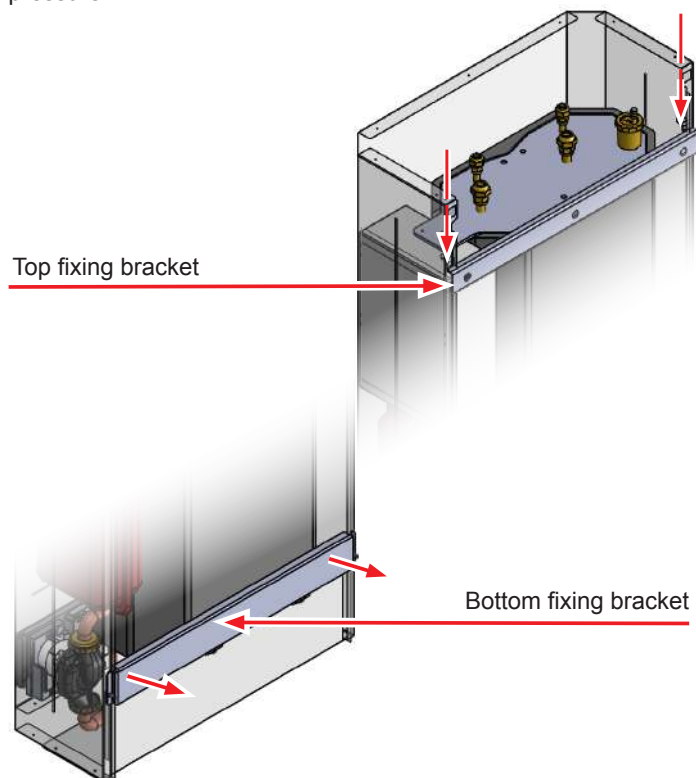

#### 4.3 HANGING INDOOR UNIT DIMENSIONS HUB RADIATOR MINI

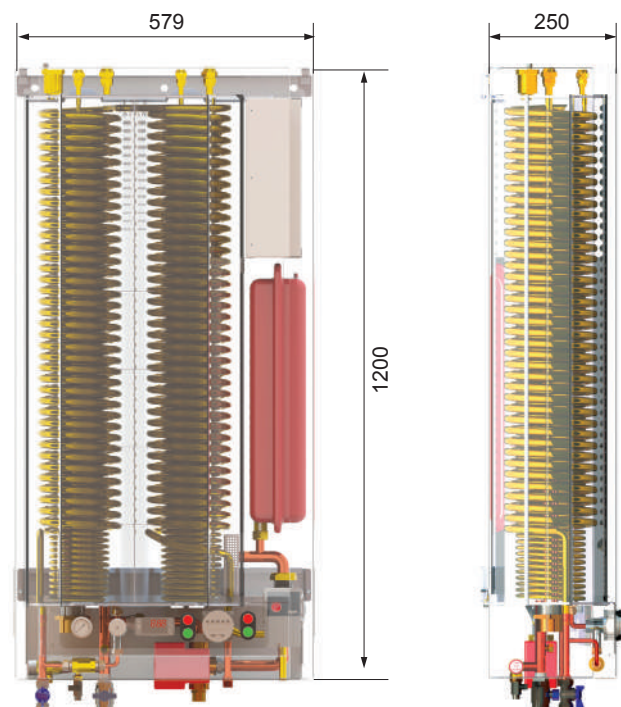

values expressed in mm

#### 4.2 DIMENSIONS AND TECHNICAL DATA OUTDOOR UNITS BOOSTER HUB RADIATOR MINI

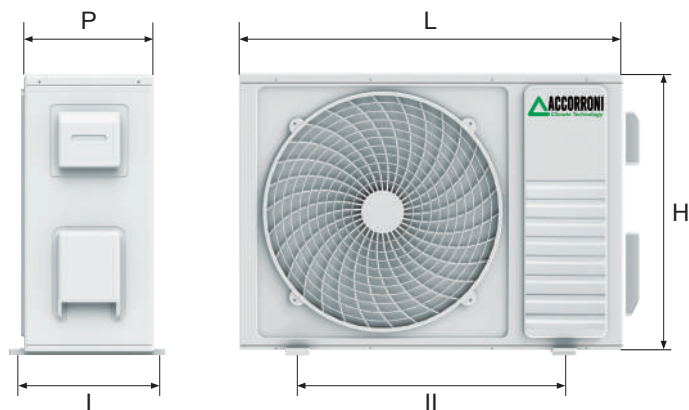

Booster	L mm	H mm	P mm	I mm	II mm
HR 3.0	700	552	256	275	435
HR 7.8	830	585	300	330	515

#### Booster technical data

	U.M.	HR 3.0	HR 7.8
Refrigerant quantity	Kg	1,1	1,5
Refrigerant gas connections		3/8"	5/8"
Coolant fluid connections		1/4"	1/4"
Power supply		230V/1/50Hz	
Sound level*	dB(A)	52*	58*
Weight	Kg	33	55

\* Value measured at one meter from the sound source in free field

#### 4.4 FLUSH-MOUNTED INDOOR UNIT DIMENSIONS HUB RADIATOR MINI

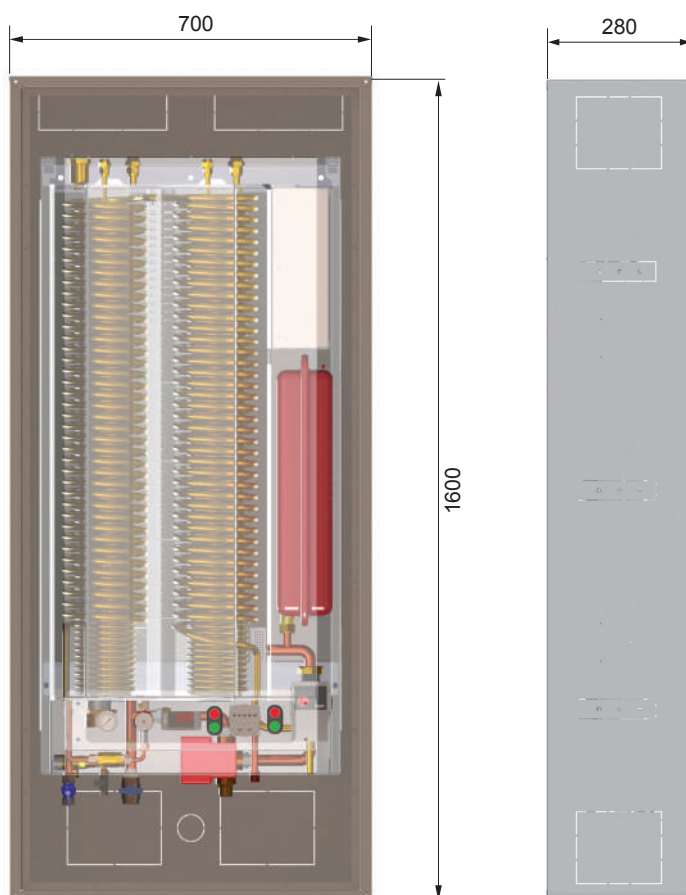

#### 4.5 PERFORMANCE FEATURES OUTDOOR UNIT BOOSTER HR 3.0



#### BOOSTER HR 3.0 - THERMAL POWER DELIVERED

Thermal power output kW

Heating water delivery temperature °C

Ta (°C)	30	35	40	45	50	55
- 10	1,96	1,93	1,88	1,80	1,67	1,51
- 9	2,02	1,99	1,94	1,86	1,74	1,58
- 8	2,08	2,05	2,01	1,93	1,81	1,66
- 7	2,14	2,11	2,07	1,99	1,88	1,74
- 6	2,20	2,18	2,13	2,06	1,96	1,81
- 5	2,27	2,24	2,20	2,13	2,03	1,89
- 4	2,33	2,31	2,26	2,19	2,10	1,96
- 3	2,40	2,37	2,33	2,26	2,17	2,04
- 2	2,47	2,44	2,39	2,33	2,24	2,11
- 1	2,54	2,51	2,46	2,40	2,31	2,18
0	2,61	2,58	2,53	2,47	2,38	2,26
1	2,69	2,65	2,60	2,54	2,45	2,33
2	2,76	2,71	2,67	2,61	2,52	2,40
3	2,84	2,80	2,74	2,68	2,59	2,47
4	2,92	2,87	2,82	2,75	2,66	2,55
5	3,01	2,95	2,89	2,82	2,73	2,62
6	3,09	3,03	2,97	2,90	2,81	2,69
7	3,18	3,11	3,05	2,97	2,88	2,77
8	3,27	3,20	3,12	3,05	2,95	2,84
9	3,36	3,28	3,20	3,12	3,03	2,91
10	3,45	3,37	3,29	3,20	3,10	2,98
11	3,55	3,46	3,37	3,28	3,18	3,06
12	3,64	3,59	3,45	3,36	3,25	3,13
13	3,75	3,64	3,54	3,44	3,33	3,20
14	3,85	3,74	3,63	3,52	3,41	3,28
15	3,95	3,83	3,72	3,60	3,48	3,35

#### BOOSTER HR 3.0

#### ABSORBED ELECTRIC POWER KW

Heating water delivery temperature °C

Ta (°C)	30	35	40	45	50	55
- 10	0,66	0,75	0,84	0,94	1,05	1,19
- 9	0,66	0,75	0,84	0,94	1,06	1,19
- 8	0,66	0,75	0,84	0,94	1,06	1,19
- 7	0,66	0,75	0,84	0,94	1,06	1,19
- 6	0,66	0,75	0,84	0,94	1,06	1,19
- 5	0,66	0,75	0,84	0,94	1,06	1,19
- 4	0,66	0,74	0,84	0,94	1,06	1,20
- 3	0,66	0,74	0,84	0,94	1,06	1,20
- 2	0,66	0,74	0,84	0,94	1,06	1,20
- 1	0,66	0,74	0,84	0,94	1,06	1,20
0	0,66	0,74	0,84	0,94	1,06	1,20
1	0,66	0,74	0,84	0,94	1,06	1,20
2	0,66	0,74	0,84	0,94	1,06	1,20
3	0,66	0,74	0,84	0,94	1,06	1,20
4	0,66	0,74	0,83	0,94	1,06	1,20
5	0,65	0,74	0,83	0,94	1,06	1,20
6	0,65	0,74	0,83	0,94	1,06	1,20
7	0,65	0,74	0,83	0,94	1,06	1,20
8	0,65	0,74	0,83	0,94	1,06	1,20
9	0,65	0,73	0,83	0,94	1,06	1,20
10	0,65	0,73	0,83	0,94	1,06	1,20
11	0,65	0,73	0,83	0,94	1,06	1,20
12	0,65	0,73	0,82	0,93	1,06	1,20
13	0,64	0,73	0,82	0,93	1,06	1,20
14	0,64	0,73	0,82	0,93	1,06	1,20
15	0,64	0,72	0,82	0,93	1,05	1,20

#### BOOSTER HR 3.0

#### C.O.P. THERMAL POWER / ABSORBED POWER

Heating water delivery temperature °C

Ta (°C)	30	35	40	45	50	55
- 10	2,96	2,59	2,25	1,91	1,59	1,27
- 9	3,04	2,67	2,32	1,98	1,65	1,33
- 8	3,14	2,75	2,39	2,05	1,71	1,39
- 7	3,23	2,81	2,47	2,11	1,78	1,46
- 6	3,32	2,92	2,54	2,19	1,84	1,52
- 5	3,42	3,01	2,62	2,26	1,91	1,58
- 4	3,52	3,10	2,70	2,33	1,97	1,64
- 3	3,63	3,19	2,78	2,40	2,04	1,70
- 2	3,74	3,28	2,86	2,47	2,10	1,76
- 1	3,85	3,37	2,94	2,54	2,17	1,82
0	3,96	3,48	3,02	2,67	2,23	1,88
1	4,08	3,57	3,11	2,69	2,30	1,94
2	4,20	3,67	3,20	2,76	2,37	2,00
3	4,33	3,78	3,29	2,84	2,43	2,06
4	4,46	3,88	3,38	2,92	2,50	2,12
5	4,59	4,00	3,47	3,00	2,57	2,18
6	4,73	4,11	3,57	3,08	2,64	2,24
7	4,87	4,20	3,66	3,16	2,71	2,30
8	5,01	4,35	3,76	3,24	2,78	2,36
9	5,16	4,47	3,86	3,33	2,85	2,42
10	5,32	4,60	3,97	3,42	2,92	2,48
11	5,48	4,73	4,08	3,51	3,00	2,54
12	5,64	4,86	4,19	3,60	3,07	2,61
13	5,81	5,00	4,30	3,69	3,15	2,67
14	5,99	5,15	4,42	3,78	3,23	2,74
15	6,17	5,29	4,54	3,88	3,31	2,80

#### 4.6 PERFORMANCE CHARACTERISTICS OF THE OUTDOOR UNIT BOOSTER HR 7.8



#### BOOSTER HR 7.8 - THERMAL POWER DELIVERED

Thermal power output kW  
Heating water delivery temperature °C

Ta (°C)	30	35	40	45	50	55
- 10	5,12	5,05	4,91	4,69	4,36	3,93
- 9	5,27	5,20	5,07	4,86	4,55	4,13
- 8	5,43	5,36	5,23	5,03	4,73	4,33
- 7	5,58	5,52	5,40	5,20	4,92	4,53
- 6	5,75	5,68	5,56	5,37	5,10	4,73
- 5	5,91	5,85	5,73	5,55	5,28	4,92
- 4	6,09	6,02	5,90	5,72	5,47	5,12
- 3	6,26	6,19	6,07	5,90	5,65	5,31
- 2	6,44	6,36	6,25	6,08	5,83	5,50
- 1	6,63	6,54	6,43	6,26	6,02	5,70
0	6,82	6,73	6,61	6,44	6,20	5,89
1	7,01	6,91	6,79	6,62	6,39	6,08
2	7,21	7,10	6,97	6,80	6,57	6,27
3	7,42	7,30	7,16	6,99	6,76	6,46
4	7,63	7,50	7,35	7,17	6,94	6,65
5	7,84	7,70	7,55	7,36	7,13	6,84
6	8,06	7,91	7,75	7,56	7,32	7,03
7	8,29	8,12	7,95	7,75	7,51	7,22
8	8,52	8,34	8,15	7,95	7,70	7,41
9	8,76	8,56	8,36	8,15	7,90	7,60
10	9,00	8,79	8,57	8,35	8,09	7,79
11	9,25	9,02	8,79	8,55	8,29	7,98
12	9,51	9,26	9,01	8,76	8,49	8,17
13	9,77	9,50	9,24	8,97	8,69	8,36
14	10,04	9,75	9,47	9,19	8,89	8,56
15	10,32	10,00	9,70	9,40	9,09	8,75

#### BOOSTER HR 7.8

#### ABSORBED ELECTRIC POWER KW

Heating water delivery temperature °C

Ta (°C)	30	35	40	45	50	55
- 10	1,78	2,00	2,25	2,52	2,83	3,19
- 9	1,78	2,00	2,25	2,53	2,84	3,19
- 8	1,78	2,00	2,25	2,53	2,84	3,20
- 7	1,78	2,00	2,25	2,53	2,84	3,20
- 6	1,78	2,00	2,25	2,53	2,85	3,21
- 5	1,78	2,00	2,25	2,53	2,85	3,21
- 4	1,78	2,00	2,25	2,53	2,85	3,22
- 3	1,78	2,00	2,25	2,53	2,86	3,22
- 2	1,77	2,00	2,25	2,54	2,86	3,23
- 1	1,77	2,00	2,25	2,54	2,86	3,23
0	1,77	2,00	2,25	2,54	2,86	3,23
1	1,77	1,99	2,25	2,53	2,86	3,23
2	1,77	1,99	2,25	2,53	2,86	3,23
3	1,76	1,99	2,24	2,53	2,86	3,23
4	1,76	1,99	2,24	2,53	2,86	3,23
5	1,76	1,98	2,24	2,53	2,86	3,23
6	1,76	1,98	2,24	2,53	2,86	3,23
7	1,75	1,98	2,23	2,52	2,86	3,23
8	1,75	1,98	2,23	2,52	2,85	3,23
9	1,75	1,97	2,23	2,52	2,85	3,23
10	1,74	1,97	2,22	2,52	2,85	3,23
11	1,74	1,96	2,22	2,51	2,85	3,23
12	1,73	1,95	2,22	2,51	2,84	3,22
13	1,73	1,95	2,21	2,50	2,84	3,22
14	1,73	1,95	2,21	2,50	2,83	3,22
15	1,72	1,95	2,20	2,49	2,83	3,21

#### BOOSTER HR 7.8

#### C.O.P. THERMAL POWER / ABSORBED POWER

Heating water delivery temperature °C

Ta (°C)	30	35	40	45	50	55
- 10	2,87	2,52	2,18	1,91	1,54	1,23
- 9	2,96	2,60	2,25	1,98	1,60	1,29
- 8	3,05	2,68	2,33	2,05	1,67	1,35
- 7	3,14	2,76	2,40	2,05	1,73	1,41
- 6	3,23	2,84	2,47	2,19	1,79	1,47
- 5	3,32	2,92	2,55	2,26	1,85	1,53
- 4	3,42	3,01	2,62	2,33	1,92	1,59
- 3	3,53	3,09	2,70	2,40	1,98	1,65
- 2	3,63	3,18	2,78	2,47	2,04	1,71
- 1	3,74	3,28	2,86	2,54	2,11	1,77
0	3,85	3,37	2,94	2,53	2,17	1,82
1	3,96	3,47	3,02	2,69	2,23	1,88
2	4,08	3,62	3,10	2,68	2,30	1,94
3	4,20	3,67	3,19	2,84	2,36	2,00
4	4,33	3,77	3,28	2,92	2,43	2,06
5	4,46	3,88	3,37	3,00	2,49	2,11
6	5,59	3,99	3,46	3,08	2,56	2,17
7	4,73	4,14	3,56	3,07	2,63	2,23
8	4,87	4,25	3,65	3,24	2,70	2,29
9	5,02	4,36	3,75	3,33	2,77	2,35
10	5,17	4,50	3,86	3,42	2,84	2,41
11	5,32	4,62	3,96	3,51	2,91	2,47
12	5,48	4,74	4,07	3,49	2,98	2,53
13	5,65	4,87	4,18	3,69	3,06	2,60
14	5,82	5,02	4,29	3,78	3,14	2,66
15	5,99	5,15	4,41	3,88	3,21	2,72

#### 4.7 ACS HUB RADIATOR MINI WITHDRAWAL TABLE

DESCRIPTION	U.M.	6.0	8.0	11.0	16.0**
DHW withdrawal at 40 °C - storage at 55 °C - inlet water at 10 °C	l	50	51	52	54
DHW withdrawal at 40 °C - storage at 55 °C - inlet water at 15 °C	l	60	62	64	66
HP recovery time from 38 °C to 55 °C - Outdoor temp. 7 °C*	min	21	18	14	8
HP recovery time + resistance from 38 °C to 58 °C - External temp. 7 °C*	min	17	15	11	7
Water withdrawal at 40 °C with storage at 62 °C with inlet water at 10 °C	l	62	63	65	67
Water withdrawal at 40 °C with storage at 62 °C with inlet water at 15 °C	l	76	77	80	82
HP recovery time + heating element from 38 °C to 62 °C - External temp. 7 °C*	min	25	22	16	10
Recovery time from 10 °C to 55 °C - Outdoor temp. 7 °C*	min	45	39	30	19

\*Data calculated with the heating system off

\*\*Continuous domestic hot water supply on a single user of 7 liters per minute (water inlet 10 °C - outlet 40 °C - external temperature 7 °C)

#### 4.8 HUB RADIATOR MINI TECHNICAL DATA TABLE

DESCRIPTION	U.M.	HR MINI 6.0	HR MINI 8.0	HR MINI 11.0	HR MINI 16.0
Thermal power (1)	kW	6,22	8,12	11,23	16,24
Absorbed power (1)	kW	1,48	1,96	2,70	3,92
C.O.P. (1)	W/W	4,20	4,14	4,16	4,14
Thermal power (2)	kW	5,94	7,75	10,72	15,50
Absorbed power (2)	kW	1,88	2,52	3,46	5,04
C.O.P. (2)	W/W	3,16	3,07	3,10	3,08
Thermal power (3)	kW	5,16	6,73	9,31	13,47
Absorbed power (3)	kW	1,48	2,00	2,74	4,00
C.O.P. (3)	W/W	3,48	3,37	3,40	3,37
Thermal power (4)	kW	4,94	6,44	8,91	12,88
Absorbed power (4)	kW	1,88	2,54	3,48	5,08
C.O.P. (4)	W/W	2,67	2,53	2,56	2,53
Thermal power (5)	kW	4,22	5,52	7,63	11,04
Absorbed power (5)	kW	1,50	2,00	2,75	4,00
C.O.P. (5)	W/W	2,81	2,76	2,77	2,76
Thermal power (6)	kW	3,98	5,20	7,19	10,40
Absorbed power (6)	kW	1,88	2,53	3,47	5,06
C.O.P. (6)	W/W	2,11	2,05	2,07	2,06
S.C.O.P. (7)	W/W	3,78	3,71	3,72	3,71
Seasonal heating efficiency (η <sub>s</sub> )	%	153,1	150,3	150,6	150,3
Energy efficiency (8)		A / A++			
Defrosting method		Reverse cycle with immersion condenser			
Type of refrigerant		R410A			
Technical water temperature min / max	°C	+ 30 / + 58			
Amount of refrigerant (pre-inserted)	kg	1,1 x 2	1,5	1,5 + 1,1	1,5 x 2
Min distance between outdoor and indoor unit	m	3			
Max distance between outdoor and indoor unit without recharging	m	5			
Max distance between outdoor and indoor unit with recharge	m	15			
Max difference in height between outdoor and indoor unit	m	5			
Refrigerant gas line connection		3/8" x 2	5/8"	5/8" - 3/8"	5/8" x 2
Coolant fluid line connection		1/4" x 2	1/4"	1/4" - 1/4"	1/4" x 2
External temperature operating limits	°C	-15 / +45			
Indoor unit technical water content	l	70			
Max flow rate electronic inverter circulator	m <sup>3</sup> /h	3,3			
Max head electronic inverter circulator	m	6,2			
Electric absorption electronic inverter circulator	W	3 - 45			
Expansion vessel volume	l	8			
Expansion vessel preload	bar	1			
Safety valve calibration	bar	3			
Back up electric heater	W	1500			
Power supply		230V/1/50Hz			
Cold water inlet and DHW outlet hydraulic connections		1/2" M			
System delivery and return hydraulic connections		3/4" M			
Internal unit accumulation heat loss	kWh/24h	1,82			
Transport / operating indoor unit weight	kg	79 / 134	70 / 125	79 / 134	79 / 134
Outdoor unit weight	kg	33 x 2	55	55 + 33	55 x 2

(1) Heating: external air temperature 7 °C d.b. - 6 °C b.u. ; inlet / outlet water temperature 30/35 °C

(2) Heating: external air temperature 7 °C d.b. - 6 °C b.u. ; inlet / outlet water temperature 40/45 °C

(3) Heating: external air temperature 0 °C d.b. ; inlet / outlet water temperature 30/35 °C

(4) Heating: external air temperature 0 °C d.b. ; inlet / outlet water temperature 40/45 °C

(5) Heating: external air temperature -7 °C d.b. ; inlet / outlet water temperature 30/35 °C

(6) Heating: outside air temperature -7 °C d.b. ; inlet / outlet water temperature 40/45 °C

(7) Heating: average climatic conditions; inlet / outlet water temperature 30/35 °C

(8) Water 35 °C / 55 °C

#### 4.9 ACCESSORIES HUB RADIATOR MINI



REMOTE CONTROL AND COMMAND PANEL



LOAD CONTROL RELAY FOR MANAGEMENT OF THE ABSORBED POWER



MIXING VALVE FOR RADIANT SYSTEMS FOR MOD. WITH FIXED AND MOTORIZED ADJUSTMENT



CONDENSATORE AGGIUNTIVO PER BOOSTER HR SOLO CALDO



ANCHORING BRACKET FOR INCLINED ROOF FOR EXTERNAL BOOSTERS MOD. HR 3.0 - 7.8 - 9.0  
RUBBER ANTI-VIBRATION SYSTEMS INCLUDED



ANCHORING SHELF FOR EXTERNAL BOOSTER  
RUBBER ANTI-VIBRATION SYSTEMS INCLUDED



ANTI-VIBRATION FLOOR BASE IN VULCANIZED RUBBER (HEIGHT FROM THE GROUND MM 95) WITH LEVEL AND SCREWS FOR BOOSTER HR 3.0 - 7.8 - 9.0



ANTI-VIBRATION KIT FOR INSTALLATION ON SHELVES



COMPLETE STAINLESS STEEL SPRING ANTIVIBRATION KIT OF BOLTS - WASHERS - NUTS



1/2" DHW MIXING VALVE KIT



AUXILIARY BASIN FOR INSTALLATION UNDER SHELF EQUIPPED WITH 90 W HEATING CABLE



CONDENSATE ANTIFREEZE HEATING CABLE WITH THERMAL SENSOR, FACTORY FITTED



FLOOR SUPPORT COMPLETE WITH AUXILIARY BASIN EQUIPPED WITH 90 W HEATING CABLE



FACTORY MADE HYBRID SYSTEM ELECTRONIC MANAGEMENT KIT WITH CONNECTION SLEEVES FOR ADDITIONAL THERMAL GENERATOR



FLEXIBLE ANTI-VIBRATION JOINT KIT WITH FOLDER OF FITTING AND STRAIGHT UNION



FLEXIBLE ANTI-VIBRATION JOINT KIT WITH FOLDER OF CONNECTION AND 90° CURVED UNION





**OPEN SHELF FOR N. 2 OUTDOOR BOOSTER UNITS  
MOD. HR 3.0 - 7.8 COMPLETE WITH ANTIVIBRATION**



**RACK 2 CABINET N. 2 OUTDOOR UNITS BOOSTER  
MOD. HR 3.0 - 7.8**

**5. DIGITAL CONTROL UNIT HUB RADIATOR MINI**



**5.1 DISPLAY**

Information available on the display:

- Primary display (red color): display configurable by parameter CF36 (PB1, PB2, PB4, Set-point (parameter value)\*, Real set point\*, Hysteresis, Status machine\*\*);
- Secondary display (yellow color) display configurable by parameter CF43 (PB1, PB2, PB3, PB4, Set-point (from parameter) \*, Real set-point\* Hysteresis, RTC, Machine status\*\*);

\*the display shows the chiller set when the unit is on in chiller mode, the HP set when the unit is switched on in HP mode, OFF with unit in stand by;















\*\* the display shows OnC when the unit is switched on in chiller, OnH when the unit is switched on in HP OFF mode with unit in stand by. unit in stand by.

**5.2 DISPLAY ICONS**

Lit when the display displays a temperature or a press	°C -°F BAR-PSI
Lit when the lower display displays the current time, the hours of operation of loads, etc.	
Flashing on in the presence of an alarm	
On if an automatic Set-point modification function is active (Dynamic set point, function for machines without accumulation, Energy Saving); if the function is enabled but not active the icon is off	<b>Vset</b>

Lit during access to the functions menu	<b>MENU</b>
On if the resistances are on (antifreeze heaters, boiler)	
On flashing during the interval count between defrosts; the icon is steady on during the phase defrost	
Flashing on if the entrance digital flow switch is active (both with pump ON and with pump OFF)	<b>Flow!</b>
On if at least one of the 2 water pumps (evaporator pump or pump capacitor) is on	
On if the fans are on	
On if the relative compressor is switched on; is flashing if the compressor is in ignition timing	
On if the exit open collector is activ	
On if the machine is on e represents the operating status Heat or Cool according to logic set in parameter CF31	
The HP icon and the LP icon are on flashing in the event of a High alarm o Low pressure active.	<b>LP HP</b>

### 5.3 KEY FUNCTION

FUNCTION	KEY
Press and release in main view: allows viewing of the set point chiller ( <b>SetC</b> label) or heat pump ( <b>SetH</b> label).	
<b>Press and release 2 times in main view:</b> if the energy saving function, dynamic set point or for machines without accumulation is enabled, the set icon is on and the display shows the real working set.	
<b>Press for 3 seconds and release in main view:</b> allows modification of the set point chiller / PdC.	
<b>Press and release in programming:</b> allows you to access the edit of the selected parameter; allows confirmation of the set value in phase of parameter modification.	
<b>Press and release in the ALrM menu:</b> allows the reset of the alarm (if resettable) from the ALrM menu.	
<b>Press and release:</b> from main view allows the display of the probe values configured (temperatures / pressures) in the upper display and the corresponding label in the lower display.	
<b>Press and release in programming:</b> allows you to scroll through folders parameters (ST, CF, etc); allows it scrolling the list of parameters. Parameter being edited increases its value.	
<b>Press and release:</b> from main view allows the display of the probe values configured (temperatures / pressures) in the upper display and the label corresponding in the lower display.	
<b>Press and release:</b> allows you to turn on the machine (in chiller or heat pump) or select std-by mode.	
<b>Press and release:</b> allows you to turn on the machine (in chiller or heat pump) or select std-by mode.	
<b>Press and release:</b> allows you to access the functions menu. Press for 3 seconds and release: allows you to adjust the clock in the models in which it is provided. Press and release in programming: allows to exit from the parameter modification.	
<b>Simultaneous pressing of the keys for 3 seconds:</b> allows access to programming parameters.	  



#### Simultaneous pressing of the keys for 3 seconds:

- allows you to exit the parameter programming.
- the simultaneous pressure Prolonged keys allows manual defrosting.





As regards the use of the remote terminal (indications on the display and meaning of the keys) refer to the previous paragraphs. In the air / air units, if the remote terminal equipped with an NTC probe (VICXS610) is used, by configuring par. CF35 = 2 the display will show the ambient air temperature; this probe will be used by the controller for thermoregulation. In the event of a fault in the controller / remote terminal or an error in the wiring, the lack of communication between the instrument and the remote terminal will be signaled on the display with the error message "noL" (no link).

#### 5.4 ACCESS TO PARAMETERS

- Press the SET and down arrow keys for a few seconds;
- The icons   flash and the upper display displays "ALL" (generic group of parameters);
- Scroll through the parameter groups with the keys and select the group containing the parameters to be modified; pressing the button set allows you to access the list of parameters contained in the group. The lower display shows the parameter label and the upper display shows the value.

#### 5.5 VIEW AND MODIFY THE SET POINT

Pressing and releasing the **SET** key allows the set point to be displayed. Pressing the **SET** key for a long time allows its modification:

- Press the **SET** button for at least 3 seconds;
- The set point will be displayed flashing;
- To modify the value, use the keys  And 
- Save the new set point by pressing the **SET** or button wait for the time out time to exit the program.



User interface



Remote terminal

## 5.6 MAIN ALARMS

Cod.	Meaning	It causes	Action	Reset
<b>P1</b>	Probe alarm PB1	Probe faulty our resistive value out of range	Activate output open collector / relè alarm Activate buzzer Flashing icon generic alarm Code on display	<b>Automatic</b> if the value is within the expected range
<b>P2</b>	Probe alarm PB2	Probe faulty our resistive value out of range	Activate output open collector / relè alarm Activate buzzer Flashing icon generic alarm Code on display	<b>Automatic</b> if the value is within the expected range
<b>P3</b>	Probe alarm PB3	Probe faulty our resistive value out of range	Activate output open collector / relè alarm Activate buzzer Flashing icon generic alarm Code on display	<b>Automatic</b> if the value is within the expected range
<b>P4</b>	Probe alarm PB4	Probe faulty our resistive value out of range	Activate output open collector / relè alarm Activate buzzer Flashing icon generic alarm Code on display	<b>Automatic</b> if the value is within the expected range
<b>A12</b>	Defrost error alarm	End defrost for maximum time	Code on display reporting only	<b>Automatic</b> with subsequent correct defrost cycle
<b>A09</b>	Compressor thermal alarm	Condensation start temperature of 110 °C	Activate output open collector / relè alarm defrost icon flashing Generic alarm Code on display	<b>Automatic</b> with subsequent correct defrost cycle
<b>ALOC</b>	Low or high voltage alarm or higher than 256V	Power supply voltage below 220V activates Buzzer	Activate output open collector / relè alarm defrost icon flashing Generic alarm Code on display	<b>Automatic</b> it becomes manual after AL20 interventions now <b>Manual</b> Deactivation: digital input not active for continuous time >AL22
<b>E01</b>	Refrigerant circuit high pressure alarm	Refrigerant circuit pressure higher than 42 bar	Activate output open collector / flashing generic alarm icon	<b>Manual</b>
<b>E02</b>	Refrigerant circuit high pressure alarm	Refrigerant circuit pressure below 2,7 bar	Activate output open collector / flashing generic alarm icon	<b>Manual</b>

## 5.7 TABLE OF TROUBLESHOOTING CAUSES

Alarm Code	Broken down	Meaning	It causes	Remedy
<b>P1</b>	Probe alarm PB1	Probe technical water	1)Probe interrupted 2)Probe shorted 3)Control unit faulty	1) Technical water probe replacement 2) Control unit replacement
<b>P2</b>	Probe alarm PB2 temperature	Probe external 3)	1)Probe interrupted 2)Probe shorted 3) Probe connection Q.E. interrupted	1) External probe replacement 2) Replacement of the external probe connection cable 3) Control unit replacement
<b>P3</b>	Probe alarm PB3	Probe external temperature	1) Probe interrupted 2) Probe shorted 3) Probe connection Q.E. interrupted	1) External probe replacement 2) Replacement of the external probe connection cable 3) Control unit replacement
<b>A09</b>	Compressor thermal alarm	High temperature thermostat contact open	1)Faulty thermostat 2)Exhaust booster 3)Q.E. thermostat connection	1) Thermostat replacement 2) External Booster Charging 3) Replacement of the Q.E. thermostat connection cable
<b>A12</b>	Defrost error alarm	End defrost or maximum time	1)Lack of refrigerant gas 2)Extreme outdoor conditions 3)Condensate drain blocked 4)PB3 probe out of range	1) External Booster Charging 2) Change of parameters DF03 and DF04 3) Make sure that the condensate drains off regularly 4) Probe replacement PB3
<b>ALOC</b>	Low or high voltage alarm	Power supply voltage out of safety range	1) Power supply below 220V 2) Power supply above 253 V	Contact the electricity supplier to have the exact voltage values restored
<b>E01</b>	High pressure refrigerant gas alarm	Refrigerant gas pressure higher than 42 bar	Technical water storage	Fill the accumulation with technical water
<b>E02</b>	Low refrigerant gas circuit alarm	Gas pressure below 2.7 bar	1)Faulty evaporator fan 2)Exhaust booster 3)Presence of evaporator ice	1) Replace the evaporator fan 2) Charge refrigerant gas in the Booster 3) Check defrost parameters

## 6. PARAMETER TABLES

### 6.1 SUBMENU SELECTION

LABEL	MEANING
ALL	View all parameters
ST	It displays only the thermoregulation parameters
CF	It displays only the configuration parameters
SD	It displays only the dynamic set point parameters
ES	It displays only the energy saving parameters
CO	It displays only the compressor parameters
FA	It displays only the ventilation parameters
Ar	It displays only the frost resistance parameters
DF	It displays only the defrost parameters
AL	It displays only the alarm parameters

### 6.2 CONFIGURATION PARAMETERS

Parametri Termoregolazione					
Parametro	Descrizione	min	max	udm	Risoluzione
ST01	Set point estate	ST05	ST06	°C/°F	dec/int
ST02	Differenziale estate	0.0 0	25.0 45	°C °F	Dec int
ST03	Set point inverno	ST07	ST08	°C/°F	dec/int
ST04	Differenziale inverno	0.0 0	25.0 45	°C °F	Dec int
ST05	Set minimo estate	-50.0 -58	ST01	°C °F	Dec int
ST06	Set massimo estate	ST01	110 230	°C °F	Dec int
ST07	Set minimo inverno	-50.0 -58	ST03	°C °F	Dec int
ST08	Set massimo inverno	ST03	110 230	°C °F	Dec int
ST09	Banda di regolazione	0.0 0	25.0 45	°C °F	Dec int
Funzione senza accumulo					
Parametro	Descrizione	min	max	udm	Risoluzione
ST10	Funzione unità chiller senza accumulo 0= disabilitata 1= abilitata	0	1		
ST11	Set point minima temperatura acqua in uscita unità senza accumulo in funzionamento chiller	-50.0 -58	110 230	°C °F	Dec int
ST12	Set point massima temperatura acqua in uscita unità senza accumulo in funzionamento p.d.c.	-50.0 -58	110 230	°C °F	Dec int
ST13	Delta set point in funzionamento chiller / p.d.c.	0.0 0	25.0 45	°C °F	Dec int
ST14	Delta differenziale in funzionamento chiller / p.d.c.	0.0 0	25.0 45	°C °F	Dec int
ST15	Tempo funzionamento compressore superato il quale viene decrementato il delta set point e il delta differenziale in funzionamento chiller / p.d.c.	0	250	Sec	10 sec
ST16	Costante per il calcolo del valore set point e differenziale in funzionamento chiller / p.d.c.	0	250		
ST17	Tempo di ritardo modifica del set point di lavoro	1	250	Sec	10 sec
Funzione Chiller geotermico					
Parametro	Descrizione	min	max	udm	Risoluzione
ST18	Set point ambiente in chiller	ST20	ST21	°C/°F	dec/int
ST19	Differenziale ambiente in chiller	0.0 0	25.0 45	°C °F	Dec int
ST20	Set minimo ambiente in chiller	-50.0 -58	ST18	°C °F	Dec int
ST21	Set massimo ambiente in chiller	ST18	110 230	°C °F	Dec int
ST22	Set point ambiente in p.d.c.	ST24	ST25	°C/°F	dec/int
ST23	Differenziale ambiente in p.d.c.	0.0 0	25.0 45	°C °F	Dec int
ST24	Set minimo ambiente in p.d.c.	-50.0 -58	ST22	°C °F	Dec int
ST25	Set massimo ambiente in p.d.c.	ST22	110 230	°C °F	Dec int
Pr2	Password	0	999		

Parametri Configurazione					
Parametro	Descrizione	min	max	udm	Risoluzione
CF01	Tipo di unità: 0= Chiller aria / aria 1= Chiller aria / acqua 2= Chiller acqua / acqua 3= Chiller acqua / acqua con inversione ciclo lato acqua	0	3		
CF02	Motocondensante 0= No 1= Si	0	1		
CF03	Sonda di regolazione 0= Regola sulla sonda PB1 1= Regola sulla sonda PB2 2= Regola sulla sonda PB2 e abilita il funzionamento con set utente sulla sonda PB1	0	2		
CF04	Configurazione PB1 0= Sonda assente 1= Temperatura NTC ingresso evaporatore 2= Ingresso digitale richiesta termoregolatore 3= Ingresso digitale richiesta freddo	0	3		
CF05	Configurazione PB2 0= Sonda assente 1= Temperatura NTC uscita evaporatore 2= Ingresso digitale allarme antigelo 3= Ingresso digitale richiesta caldo 4= Temperatura aria esterna	0	4		
CF06	Configurazione PB3 0= Sonda assente 1= Temperatura NTC controllo condensazione 2= Ingresso 4...20ma per controllo condensazione 3= Ingresso 4...20ma per set point dinamico 4= Sonda di temperatura NTC per termoregolazione e allarme antigelo in unità acqua/acqua con inversione lato acqua (unità con p.d.c.) 5= Sonda NTC alta temperatura acqua ingresso impianto 6= ingresso 0...5V per controllo condensazione	0	6		
CF07	Configurazione PB4 0= sonda assente 1= Temp. NTC controllo Condensazione 2= Ingresso digitale multifunzione 3= Temperatura aria esterna 4= Temperatura NTC allarme antigelo (unità acqua/acqua) 5= Temperatura NTC sbrinamento combinato 6= Sonda di temperatura NTC per termoregolazione e allarme antigelo in unità acqua/acqua con inversione lato acqua (unità con p.d.c.) 7= Sonda NTC alta temperatura acqua ingresso impianto	0	7		
CF08	Configurazione ID1 0= Termica compressore 1 1= Termica ventilatore di condensazione 2= Flussostato evaporatore 3= On/off remoto 4= chiller / pompa di calore remoto 5= Termica compressore 2 6= Richiesta 2 compressore / gradino 7= Fine sbrinamento 8= Energy saving 9= Allarme antigelo 10= Termica compressori 1 e 2 11= Allarme generico segnalazione / blocco 12= Allarme termica pompa acqua evaporatore / termica ventilatore di mandata 13= Allarme termica pompa acqua condensatore 14= Flussostato condensatore 15= Disabilitato	0	15		

CF09	Configurazione ID2 0= Termica compressore 1 1= Termica ventilatore di condensazione 2= Flussostato evaporatore 3= On/off remoto 4= chiller / pompa di calore remoto 5= Termica compressore 2 6= Richiesta 2 compressore / gradino 7= Fine sbrinamento 8= Energy saving 9= Allarme antigelo 10= Termica compressori 1 e 2 11= Allarme generico segnalazione / blocco 12 = Allarme termica pompa acqua evaporatore / termica ventilatore di mandata 13= Allarme termica pompa acqua condensatore 14= Flussostato condensatore 15= Disabilitato	0	15		
CF10	Configurazione ID5 0= Termica compressore 1 1= Termica ventilatore di condensazione 2= Flussostato evaporatore 3= On/off remoto 4= chiller / pompa di calore remoto 5= Termica compressore 2 6= Richiesta 2 compressore / gradino 7= Fine sbrinamento 8= Energy saving 9= Allarme antigelo 10= Termica compressori 1 e 2 11= Allarme generico segnalazione / blocco 12 = Allarme termica pompa acqua evaporatore / termica ventilatore di mandata 13= Allarme termica pompa acqua condensatore 14= Flussostato condensatore 15= Disabilitato	0	15		
CF11	Configurazione PB4 se selezionato come ingresso digitale 0= Termica compressore 1 1= Termica ventilatore di condensazione 2= Flussostato 3= On/off remoto 4= chiller / pompa di calore remoto 5= Termica compressore 2 6= Richiesta 2 compressore / gradino 7= Fine sbrinamento 8= Energy saving 9= Allarme antigelo 10= Termica compressori 1 e 2 11= Allarme generico segnalazione / blocco 12 = allarme termica pompa acqua evaporatore / termica ventilatore di mandata 13= allarme termica pompa acqua condensatore 14= flussostato condensatore 15= disabilitato	0	15		
CF12	Polarità ID1 0= Attivo contatto chiuso 1= Attivo contatto aperto	0	1		
CF13	Polarità ID2 0= Attivo contatto chiuso 1= Attivo contatto aperto	0	1		
CF14	Polarità ID3 0= Attivo contatto chiuso 1= Attivo contatto aperto	0	1		
CF15	Polarità ID4 0= Attivo contatto chiuso 1= Attivo contatto aperto	0	1		
CF16	Polarità ID5 0= Attivo contatto chiuso 1= Attivo contatto aperto	0	1		
CF17	Polarità PB1 0= Attivo contatto chiuso 1= Attivo contatto aperto	0	1		
CF18	Polarità PB2 0= Attivo contatto chiuso 1= Attivo contatto aperto	0	1		
CF19	Polarità PB4 0= Attivo contatto chiuso 1= Attivo contatto aperto	0	1		
CF20	Configurazione RL4 0 = relè allarme 1 = parzializzazione compressore n° 1 2 = compressore n° 2 3 = ON/OFF ventilazione 4 = valvola di inversione 5 = resistenza antigelo / appoggio n°1 6 = solenoide lato acqua 7 = solenoide lato acqua solo in pompa di calore 8= resistenza antigelo / appoggio n° 2 9 = pompa acqua evaporatore / ventilatore di mandata (macchine aria / aria) 10= pompa acqua condensatore	0	10		
CF21	Configurazione RL5 0 = relè allarme 1 = parzializzazione compressore n° 1 2 = compressore n° 2 3 = ON/OFF ventilazione 4 = valvola di inversione 5 = resistenza antigelo / appoggio n°1 6 = solenoide lato acqua 7 = solenoide lato acqua solo in pompa di calore 8= resistenza antigelo / appoggio n° 2 9 = pompa acqua evaporatore / ventilatore di mandata (macchine aria / aria) 10= pompa acqua condensatore	0	10		
CF22	Valore di pressione a 4mA / 0,5V	0,0 0	50,0 725	Bar Psi	Dec int
CF23	Valore di pressione a 20mA / 5V	0,0 0	50,0 725	Bar Psi	Dec int

CF24	Offset PB1	-12,0 -21	12,0 21	°C °F	Dec int
CF25	Offset PB2	-12,0 -21	12,0 21	°C °F	Dec int
CF26	Offset PB3	-12,0 -21 -12,0 -174	12,0 21 12,0 174	°C °F Bar Psi	Dec int dec int
CF27	Offset PB4	-12,0 -21	12,0 21	°C °F	Dec int
CF28	Selezione chiller / pompa di calore 0= chiller e pompa con selezione da tastiera 1= chiller e pompa con selezione da ingresso digitale 2= chiller e pompa con selezione da sonda 3= solo chiller 4= solo pompa di calore	0	4		
CF29	Set Change Over Automatico	-50,0 -58	110 230	°C °F	Dec int
CF30	Differenziale selezione modo funzionamento	0,1 0	25,0 45	°C °F	Dec int
CF31	Logica di funzionamento 0= chiller / pdc 1= chiller / pdc	0	1		
CF32	Selezione °C o °F 0= °C / °BAR 1= °F / °psi	0	1		
CF33	Selezione frequenza rete 0= 50 Hz 1= 60 Hz 2 = l'uscita PWM può pilotare un relè allarme esterno	0	2		
CF34	Indirizzo seriale	1	247		
CF35	Terminale remoto 0= non utilizzato 1= modello senza sonda a bordo 2= modello con sonda NTC a bordo	0	2		
CF36	Default visualizzazione display superiore 0 = PB1 1 = PB2 2 = Niente 3 = PB4 4 = Setpoint reale unità 5 = Stato unità 6 = Niente 7 = Niente 8 = Differenziale di lavoro 9 = Setpoint unità (valore fisso del parametro)	0	9		
CF37	Release firmware				
CF38	Mapa parametri EProm				
CF39	Configurazione RL2 0 = relè allarme 1 = parzializzazione compressore n° 1 2 = compressore n° 2 3 = ON/OFF ventilazione 4 = valvola di inversione 5 = resistenza antigelo / appoggio n°1 6 = solenoide lato acqua 7 = solenoide lato acqua solo in pompa di calore 8= resistenza antigelo / appoggio n° 2 9 = pompa acqua evaporatore / ventilatore di mandata (macchine aria / aria) 10= pompa acqua condensatore	0	10		
CF40	Configurazione RL3 0 = relè allarme 1 = parzializzazione compressore n° 1 2 = compressore n° 2 3 = ON/OFF ventilazione 4 = valvola di inversione 5 = resistenza antigelo / appoggio n°1 6 = solenoide lato acqua 7 = solenoide lato acqua solo in pompa di calore 8= resistenza antigelo / appoggio n° 2 9 = pompa acqua evaporatore / ventilatore di mandata (macchine aria / aria) 10= pompa acqua condensatore	0	10		
CF41	Configurazione uscita open collector 0 = relè allarme 1 = parzializzazione compressore n° 1 2 = compressore n° 2 3 = ON/OFF ventilazione 4 = valvola di inversione 5 = resistenza antigelo / appoggio n°1 6 = solenoide lato acqua 7 = solenoide lato acqua solo in pompa di calore 8= resistenza antigelo / appoggio n° 2 9 = pompa acqua evaporatore / ventilatore di mandata (macchine aria / aria) 10= pompa acqua condensatore	0	10		
CF42	Tempo di inversione valvola su fermo compressore	0	250	Sec	
CF43	Default visualizzazione display inferiore 0 = PB1 1 = PB2 2 = PB3 3 = PB4 4 = Setpoint reale unità 5 = Stato unità 6 = Orologio 7 = Niente 8 = Differenziale di lavoro 9 = Setpoint unità (valore fisso del parametro)	0	9		

CF44	Default visualizzazione display superiore terminale remoto 0 = PB1 1 = PB2 2 = Niente 3 = PB4 4 = Setpoint reale unità 5 = Stato unità 6 = Niente 7 = Niente 8 = Differenziale di lavoro 9= Setpoint unità (valore fisso del parametro)	0	9		
CF45	Default visualizzazione display inferiore terminale remoto 0 = PB1 1 = PB2 2 = PB3 3 = PB4 4 = Setpoint reale unità 5 = Stato unità 6 = Orologio 7 = Niente 8 = Differenziale di lavoro 9= Setpoint unità (valore fisso del parametro)	0	9		
CF46	Visualizzazione in STD-BY 0 = visualizza le grandezze della visualizzazione normale (impostate con parametri CF36 e CF43) 1 = visualizza la label "OFF" 2 = visualizza la label "StbY"	0	2		
CF47	Visualizzazione in STD-BY terminali remoti 0 = visualizza le grandezze della visualizzazione normale (impostate con parametri CF36 e CF43) 1 = visualizza la label "OFF" 2 = visualizza la label "StbY"	0	2		
CF48	Configurazione uscita analogica 4..20mA / 0..10V 0 = uscita 4..20mA 1 = uscita 0..10V	0	1		
Pr2	Password	0	999		
Set Point Dinamico					
Parametro	Descrizione	min	max	udm	Risoluzione
Sd01	Set point dinamico 0= Non abilitato 1= Abilitato	0	1		
Sd02	Offset max setpoint d. estate	-30.0 -54	30.0 54	°C °F	Dec int
Sd03	Offset max setpoint d. inverno	-30.0 -54	30.0 54	°C °F	Dec int
Sd04	Set temp. Aria esterna setpoint d. estate	-50.0 -58	110 230	°C °F	Dec int
Sd05	Set temp. Aria esterna setpoint d. inverno	-50.0 -58	110 230	°C °F	Dec int
Sd06	Differenziale temp. Aria esterna setpoint d. estate	-30.0 -54	30.0 54	°C °F	Dec int
Sd07	Differenziale temp. Aria esterna setpoint d. inverno	-30.0 -54	30.0 54	°C °F	Dec int
Pr2	Password	0	999		
Energy Saving					
Parametro	Descrizione	min	max	udm	Risoluzione
ES01	Inizio (0+24)	0	23.50	Min	10 min
ES02	Fine (0+24)	0	23.50	Min	10 min
ES03	Lunedì 0 = Non abilitato 1= Abilitato	0	1		
ES04	Martedì 0 = Non abilitato 1= Abilitato	0	1		
ES05	Mercoledì 0 = Non abilitato 1= Abilitato	0	1		
ES06	Giovedì 0 = Non abilitato 1= Abilitato	0	1		
ES07	Venerdì 0 = Non abilitato 1= Abilitato	0	1		
ES08	Sabato 0 = Non abilitato 1= Abilitato	0	1		
ES09	Domenica 0 = Non abilitato 1= Abilitato	0	1		
ES10	Incremento set energy saving chiller	-30.0 -54	30.0 54	°C °F	Dec int
ES11	Differenziale energy saving chiller	0.1 0	25.0 45	°C °F	Dec int
ES12	Incremento set energy saving p.d.c.	-30.0 -54	30.0 54	°C °F	Dec int
ES13	Differenziale energy saving p.d.c.	0.1 0	25.0 45	°C °F	Dec int
Pr2	Password	0	999		
Parametri Compressori					
Parametro	Descrizione	min	max	udm	Risoluzione
CO01	Tempo minimo accensione	0	250	Sec	10Sec
CO02	Tempo minimo spegnimento	0	250	Sec	10Sec
CO03	Ritardo accensione tra i due compressori / parzializzazione	1	250	Sec	
CO04	Ritardo spegnimento tra i due compressori / parzializzazione	0	250	Sec	
CO05	Ritardo all' accensione compressori da power ON	0	250	Sec	10Sec

CO06	Ritardo ON compressore dalla partenza pompa / ventilatore di mandata	1	250	Sec	
CO07	Ritardo OFF pompa / ventilatore di mandata dallo spegnimento compressore	0	250	Sec	
CO08	Rotazione compressori 0= Abilitata 1= Sequenza fissa	0	1		
CO09	Tempo di ritardo disattivazione valvola lato acqua da OFF compressore	0	250	Sec	
CO10	Polarità valvola di parzializzazione 0= Parzializzazione. ON 1= Parzializzazione. OFF	0	1		
CO11	Modo operativo pompa / ventilatore di mandata 0= Assente 1= Funzionamento continuo in uscita ON/OFF 2= Funzionamento su chiamata del compressore 3= Funzionamento continuo in uscita 4* 20mA 4= Funzionamento su chiamata del compressore 4* 20mA	0	4		
CO12	Compressore 1 0 = Abilitato 1 = OFF	0	1		
CO13	Compressore 2 / parzializzazione. 0 = Abilitato 1= OFF	0	1		
CO14	SET Contaore compressore 1	0	999	Hr	10 Hr
CO15	SET Contaore compressore 2	0	999	Hr	10 Hr
CO16	SET Contaore pompa acqua / ventilatore di mandata (unità aria/aria)	0	999	Hr	10 Hr
Unloading evaporatore					
CO17	Set point attivazione unloading evaporatore	-50.0 -58	110 230	°C °F	Dec int
CO18	Differenziale attivazione unloading evaporatore	0.1 0	25.0 45	°C °F	Dec int
CO19	Ritardo attivazione unloading evaporatore	0	250	Sec	10 Sec
CO20	Tempo massimo di permanenza in funzionamento unloading comp da alta temp. ingresso evaporatore	0	250	Sec	10 Sec
Unloading condensatore					
CO21	Set point unloading compressore pressione in funzionamento chiller	0.0 0	50.0 725	Bar Psi	Dec int
CO22	Differenziale unloading compressore pressione in funzionamento chiller	0.0 0	12.0 174	Bar Psi	Dec int
CO23	Set point unloading compressore pressione in funzionamento pompa di calore	0.0 0	50.0 725	Bar Psi	Dec int
CO24	Differenziale unloading compressore pressione in funzionamento pompa di calore	0.0 0	12.0 174	Bar Psi	Dec int
CO25	Tempo massimo di unloading condensatore	0	250	Sec	10 Sec
Pompa acqua condensatore					
CO26	Modo operativo pompa acqua condensatore 0= Assente 1= Funzionamento continuo 2= Funzionamento su chiamata del compressore	0	2		
CO27	Ritardo OFF pompa acqua condensatore dallo spegnimento compressore	0	250	Sec	
CO28	SET Conta ore pompa acqua condensatore	0	999	Hr	10 Hr
Funzione compressore in tandem					
CO29	Tempo massimo di funzionamento continuativo compressore	0	250	Min	
CO30	Tempo di ritardo avviamento compressore dalla richiesta valvola solenoide lato acqua.	0	250	sec	10 Sec
Pompa acqua evaporatore modulante					
CO31	Tempo di spunto pompa impianto alla massima velocità da richiesta termoregolazione	0	250	sec	
CO32	Minima velocità % in funzionamento con compressore attivo (Chiller)	30	100	%	
CO33	Minima velocità % in funzionamento con compressore attivo (Pompa di calore)	30	100	%	
CO34	Velocità % pompa impianto con compressore Spento	30	100	%	
CO35	Set point controllo velocità pompa in funzione della temperatura acqua uscita (PB2) in modalità chiller	-50.0 -58	110 230	°C °F	Dec int
CO36	Banda di controllo temperatura acqua mandata in chiller	0.0 0	25.0 45	°C °F	Dec int
CO37	Tempo ritardo spegnimento comp. da termoregolazione con pompa acqua < 100 % in funzionamento chiller	0	250	sec	
CO38	Set point controllo velocità pompa in funzione della temperatura acqua mandata (PB2) in modalità Pompa di calore	-50.0 -58	110 230	°C °F	Dec int
CO39	Banda di controllo temperatura acqua mandata in pdc	0.0 0	25.0 45	°C °F	Dec int
CO40	Tempo ritardo spegnimento comp. da termoregolazione con pompa acqua < 100 % in funzionamento p.d.c.	0	250	sec	
Pr2	Password	0	999		
Parametri Ventilazione					
Parametro	Descrizione	min	max	udm	Risoluzione
FA01	Uscita ventilatori 0= Assente 1= Presente	0	1		
FA02	Regolazioni ventole 0= Accese con compressore acceso 1= Regolazione ON / OFF 2= Regolatore proporzionale di velocità	0	2		
FA03	Modo funzionamento ventole 0= Dipendenti dal compressore 1= Indipendenti dal compressore	0	1		
FA04	Tempo di spunto ventole max velocità dopo ON	0	250	Sec	
FA05	Sfasamento ventole	0	20	Micro Sec	250* s
FA06	Non adoperato				
FA07	Preventilazione in cooling prima di ON compressore	0	250	Sec	
FA08	Minima velocità ventole in estate	30	100	%	

FA09	Massima velocità ventole in estate	30	100	%	
FA10	Set temperatura / pressione minima velocità ventole in estate	-50.0 -58 0.0 0	110 230 50.0 725	°C °F Bar Psi	Dec int Dec int
FA11	Set temperatura / pressione massima velocità ventole in estate	-50.0 -58 0.0 0	110 230 50.0 725	°C °F Bar Psi	Dec int Dec int
FA12	Banda proporzionale ventilatori in estate	0.0 0 0.0 0	25.0 45 50.0 725	°C °F Bar Psi	Dec int Dec int
FA13	Differenziale CUT-OFF estate	0.0 0 0.0 0	25.0 45 50.0 725	°C °F Bar Psi	Dec int Dec int
FA14	Over ride CUT-OFF estate	0.0 0 0.0 0	25.0 45 50.0 725	°C °F Bar Psi	Dec int Dec int
FA15	Tempo ritardo CUT-OFF	0	250	Sec	
FA16	Velocità night function estate	30	100	%	
FA17	Minima velocità ventole in inverno	30	100	%	
FA18	Massima velocità ventole in inverno	30	100	%	
FA19	Set temperatura / pressione minima velocità ventole in inverno	-50.0 -58 0.0 0	110 230 50.0 725	°C °F Bar Psi	Dec int Dec int
FA20	Set temperatura / pressione massima velocità ventole in inverno	-50.0 -58 0.0 0	110 230 50.0 725	°C °F Bar Psi	Dec int Dec int
FA21	Banda proporzionale ventole in inverno	0.0 0 0.0 0	25.0 45 50.0 725	°C °F Bar Psi	Dec int Dec int
FA22	Differenziale CUT-OFF inverno	0.0 0 0.0 0	25.0 45 50.0 725	°C °F Bar Psi	Dec int Dec int
FA23	Over ride CUT-OFF inverno	0.0 0 0.0 0	25.0 45 50.0 725	°C °F Bar Psi	Dec int Dec int
FA24	Velocità night function inverno	30	100	%	
<b>Funzione Hot Start</b>					
<b>Parametro</b>	<b>Descrizione</b>	<b>min</b>	<b>max</b>	<b>udm</b>	<b>Risoluzione</b>
FA25	Set point hot start	-50.0 -58	110 230	°C °F	Dec int
FA26	Differenziale hot start	0.1 0	25.0 45	°C °F	Dec int
Pr2	Password	0	999		
<b>Parametri Resistenze Antigelo / Appoggio</b>					
<b>Parametro</b>	<b>Descrizione</b>	<b>min</b>	<b>max</b>	<b>udm</b>	<b>Risoluzione</b>
Ar01	Set point minimo antigelo	-50.0 -58	Ar03 110 230	°C °F	Dec int
Ar02	Setpoint massimo antigelo	Ar03	110 230	°C °F	Dec int
Ar03	Set allarme antigelo in chiller	Ar01	Ar02	°C / °F	Dec/int
Ar04	Differenziale allarme antigelo in chiller	0 0	25.0 45	°C °F	Dec int
Ar05	Ritardo allarme antigelo	0	250	Sec	
Ar06	Numero max interventi ora antigelo	0	16		
Ar07	Ritardo allarme antigelo alla partenza in p.d.c.	0	250	Sec	
Ar08	Set point resistenze antigelo in chiller	-50.0 -58	110 230	°C °F	Dec int
Ar09	Set point resistenze antigelo in p.d.c.	-50.0 -58	110 230	°C °F	Dec int
Ar10	Set point resistenze antigelo esterne (unità acqua/acqua)	-50.0 -58	110 230	°C °F	Dec int
Ar11	Differenziale resistenze antigelo in chiller	0.1 0	25.0 45	°C °F	Dec int
Ar12	Differenziale resistenze antigelo in p.d.c.	0.1 0	25.0 45	°C °F	Dec int
Ar13	Attivazione resistenze antigelo 0= Attivazione con termoregolatore 1= Attivazione con termoregolatore e in sbrinamento	0	1		
Ar14	Regolazione resistenze antigelo in chiller 0= OFF in chiller 1= ON in chiller	0	1		
Ar15	Regolazione resistenze antigelo in p.d.c. 0= OFF in p.d.c. 1= ON in p.d.c.	0	1		
Ar16	Termoregolazione resistenze antigelo in chiller 0= Regola su PB1 1= Regola su PB2 2= Regola su PB3 3= Regola su PB4	0	3		
Ar17	Termoregolazione resistenze antigelo in p.d.c. 0= Regola su PB1 1= Regola su PB2 2= Regola su PB3 3= Regola su PB4	0	3		
<b>Funzionamento pompa acqua evaporatore</b>					

Ar18	Regolazione pompa acqua evaporatore / resistenze antigelo in OFF-stand-by 0= Disattivata 1= Attivata 2= Regolazione pompa acqua / resistenze antigelo su sonda PB4 configurata come sonda ambiente 3 = Regolazione pompa acqua / resistenze antigelo su sonda PB4 configurata come sonda ambiente con set separati	0	3		
Ar19	Attivazione pompa acqua / resistenze antigelo in caso di guasto sonda 0= Spente con guasto sonda 1= Accese con guasto sonda	0	1		
<b>Funzione Boiler</b>					
<b>Parametro</b>	<b>Descrizione</b>	<b>min</b>	<b>max</b>	<b>udm</b>	<b>Risoluzione</b>
Ar20	Funzione boiler 0= Controllo in integrazione 1= Controllo in riscaldamento	0	1		
Ar21	Set point aria esterna attivazione resistenze boiler	-50.0 -58	110 230	°C °F	Dec int
Ar22	Differenziale resistenze boiler	0.1 0	25.0 45	°C °F	Dec int
Ar23	Tempo ritardo attivazione funzione boiler	0	250	Min	
Ar24	Tempo ritardo attivazione resistenza n° 2 boiler	0	250	Min	
Ar25	Set point aria esterna disattivazione compressori	-50.0 -58	110 230	°C °F	Dec int
Ar26	Differenziale aria esterna attivazione compressori	0.1 0	25.0 45	°C °F	Dec int
<b>Allarme antigelo in pompa di calore</b>					
Ar27	Set allarme antigelo in funzionamento p.d.c.	Ar01	Ar02	°C / °F	Dec/int
Ar28	Differenziale allarme antigelo in p.d.c.	0 0	25.0 45	°C °F	Dec int
<b>Funzionamento pompa acqua evaporatore / condensatore su sonda ambiente</b>					
Ar29	Set attivazione pompa acqua evaporatore / condensatore su sonda ambiente	-50.0 -58	110 230	°C °F	Dec int
Ar30	Differenziale attivazione pompa acqua evaporatore / condensatore su sonda ambiente	0.1 0	25.0 45	°C °F	Dec int
<b>Funzionamento pompa acqua condensatore</b>					
Ar31	Regolazione pompa acqua condensatore/ resistenze antigelo in OFF-stand-by 0= Disattivata 1= Attivata 2= Regolazione pompa acqua / resistenze antigelo su sonda PB4 configurata come sonda ambiente 3 = Regolazione pompa acqua / resistenze antigelo su sonda PB4 configurata come sonda ambiente con set separati.	0	3		
Ar32	Attivazione pompa acqua condensatore in caso di guasto sonda 0= Spente con guasto sonda 1= Accese con guasto sonda	0	1		
Pr2	Password	0	999		
<b>Parametri Sbrinamento</b>					
<b>Parametro</b>	<b>Descrizione</b>	<b>min</b>	<b>max</b>	<b>udm</b>	<b>Risoluzione</b>
dF01	Esecuzione sbrinamento 0= No 1= Si	0	1		
dF02	Modalità di sbrinamento 0= Temperatura / pressione 1= Tempo 2= Contatto esterno	0	2		
dF03	Temperatura pressione inizio sbrinamento	-50.0 -58 0.0 0	110 230 50.0 725	°C °F Bar Psi	Dec int Dec int
dF04	Temperatura pressione fine sbrinamento	-50.0 -58 0.0 0	110 230 50.0 725	°C °F Bar Psi	Dec int Dec int
dF05	Tempo minimo di attesa prima di uno sbrinamento forzato	0	250	Sec	
dF06	Durata minima sbrinamento	0	250	Sec	
dF07	Durata massima sbrinamento	0	250	min	
dF08	Tempo di attesa in OFF compressore prima dello sbrinamento	0	250	Sec	
dF09	Tempo di attesa in OFF compressore dopo lo sbrinamento	0	250	Sec	
dF10	Tempo di attesa minimo tra 2 sbrinamenti successivi	1	99	MIN	
dF11	Set temperatura inizio ciclo sbrinamento combinato dopo conteggio par. DF10	-50.0 -58	110 230	°C °F	Dec int
dF12	Set temperatura fine ciclo di sbrinamento combinato	-50.0 -58	110 230	°C °F	Dec int
dF13	Forzatura in ON secondo compressore in sbrinamento 0= Disabilitata 1= Abilitata	0	1		
dF14	Abilitazione ON ventilazione durante lo sbrinamento / gocciolamento 0= Disabilitata 1= Abilitata solo sbrinamento 2= Abilitata sbrinamento, gocciolamento (dF09)	0	2		
dF15	Set pressione / temperatura forzatura regolazione ventilazione di condensazione in sbrinamento	-50.0 -58 0.0 0	110 230 50.0 725	°C °F Bar Psi	Dec int Dec int
dF16	Allarme di minima in sbrinamento 0= Non abilitato 1= Abilitato	0	1		
dF17	Ritardo allarme di minima all'inversione della valvola 4 vie	0	250	Sec	



dF18	Valvola 4 vie di inversione ciclo 0= ON in cooling 1= ON in heating	0	1		
dF19	Set temperatura / pressione forzatura ciclo di sbrinamento	-50.0 -58 0.0 0	110 230 50.0 725	°C °F bar psi	Dec int Dec int
dF20	Differenziale forzatura ciclo di sbrinamento	0.0 0 0.0 0	25.0 45 50.0 725	°C °F Bar psi	Dec int Dec int
dF21	Blocco ventilatori in sbrinamento	0	1		
Pr2	Password	0	999		
Parametri Allarmi					
Parametro	Descrizione	min	max	udm	Risoluzione
AL01	Ritardo pressostato bassa pressione	0	250	Sec	
AL02	Numero massimo interventi ora bassa pressione	0	16		
AL03	Allarme bassa pressione con compressore spento 0= Non attivo a compressore spento 1= Attivo a compressore spento	0	1		
AL04	Ritardo allarme flussostato / termica vent. di mandata (unità aria/aria) da attivazione pompa / ventilatore	0	250	Sec	
AL05	Tempo massimo permanenza allarme flussostato prima di trasformarsi in manuale e bloccare, se in moto, la pompa dell'acqua	0	250	Sec	
AL06	Durata ingresso flussostato / termica vent. di mandata attivo	0	250	Sec	
AL07	Durata ingresso flussostato / termica vent. di mandata non attivo	0	250	Sec	
AL08	Ritardo allarme termica compressore 1-2 alla partenza	0	250	Sec	
AL09	Numero massimo interventi ora termica compressori 1-2	0	16		
AL10	Numero massimo di interventi ora allarme alta temperatura / pressione di condensazione	0	16		
AL11	Set point allarme alta temperatura / pressione di condensazione	-50.0 -58 0.0 0	110 230 50.0 725	°C °F Bar Psi	Dec int Dec int
AL12	Differenziale alta temperatura / pressione	0 0 0 0	25.0 45 50.0 725	°C °F Bar Psi	Dec int Dec int
AL13	Ritardo allarme bassa pressione ingresso analogico	0	250	Sec	
AL14	Set point allarme bassa pressione ingresso analogico	-50.0 -58 0.0 0	110 230 50.0 725	°C °F Bar Psi	Dec int Dec int

AL15	Differenziale bassa temperatura / pressione	0 0 0 0	25.0 45 50.0 725	°C °F Bar Psi	Dec int Dec int
AL16	Numero massimo interventi ora allarme bassa pressione ingresso analogico	0	16		
AL17	Abilita uscita buzzer e relè allarme in OFF o stand-by 0= Uscita buzzer e relè allarme abilitata 1= Uscita buzzer e relè allarme non abilitata	0	1		
AL18	Polarità relè allarme/uscita open collector 0= Uscita senza tensione in condizioni normali, con tensione in presenza di allarme 1= Uscita con tensione in condizioni normali, senza tensione in presenza di allarme	0	1		
AL19	Sonda per allarme antigelo: 0= Legato ai parametri Ar16 in chiller - Ar17 in p.d.c. 1= Su sonda Pb1 2= Su sonda Pb2 3= Su sonda Pb3 4= Su sonda Pb4	0	4		
AL20	Numero massimo di interventi ora allarme generico blocco unità	0	16		
AL21	Tempo di ritardo allarme generico blocco unità con ingresso digitale attivo	0	250	Sec	
AL22	Tempo di ritardo allarme generico blocco unità con ingresso digitale non attivo	0	250	10 sec	10 sec
AL23	Funzionamento allarme generico 0 = solo segnalazione non dipende da AL20 (relè allarme e buzzer attivati) sempre riarmo automatico 1= l'allarme blocca l'unità il reset dell'allarme dipende dal valore del parametro AL20	0	1		
AL24	Set point allarme alta temperatura acqua ingresso impianto	-50.0 -58	110 230	°C °F	Dec int
AL25	Differenziale allarme alta temperatura acqua in ingresso	0.1 0	25.0 45	°C °F	Dec int
AL26	Ritardo allarme alta temperatura acqua in ingresso	0	250	10 sec	10 sec
AL27	Numero massimo di interventi ora allarme alta temperatura acqua ingresso impianto	0	16		
AL28	Ritardo allarme flussostato lato caldo da attivazione / spegnimento pompa acqua	0	250	Sec	
AL29	Tempo massimo permanenza allarme flussostato lato caldo prima di trasformarsi in manuale e bloccare, se in moto, la pompa dell'acqua	0	250	Sec	
AL30	Durata ingresso flussostato lato caldo attivo (pompa non funzionante)	0	250	Sec	
AL31	Durata ingresso flussostato lato caldo non attivo (pompa funzionante)	0	250	Sec	

AL32	Funzionamento flussostato lato caldo 0= disabilitato 1= abilitato solo chiller 2= abilitato solo p.d.c. 3= abilitato chiller e p.d.c.	0	3		
Pr2	Password	0	999		

### 6.3 ELECTRICAL DIAGRAM OF DIGITAL CONTROL UNIT

**MF ID1, MF ID2, MF ID5** = multifunction digital inputs  
**HP ID3** = high pressure digital input  
**LP ID4** = low pressure digital input  
**MF RL2, MF RL3, MF RL4, MF RL5** = multifunction relay  
**Trigger signal out TK** = output for connection to external module for controlling the condensation fan (phase cut)  
**Pb1, Pb2, Pb3, Pb4** = NTC analog inputs  
**digital inputs Pb3** = ratiometric pressure translator 0.5 Vcc  
**MF o.c. out** = configurable open collector output for connection to external relay

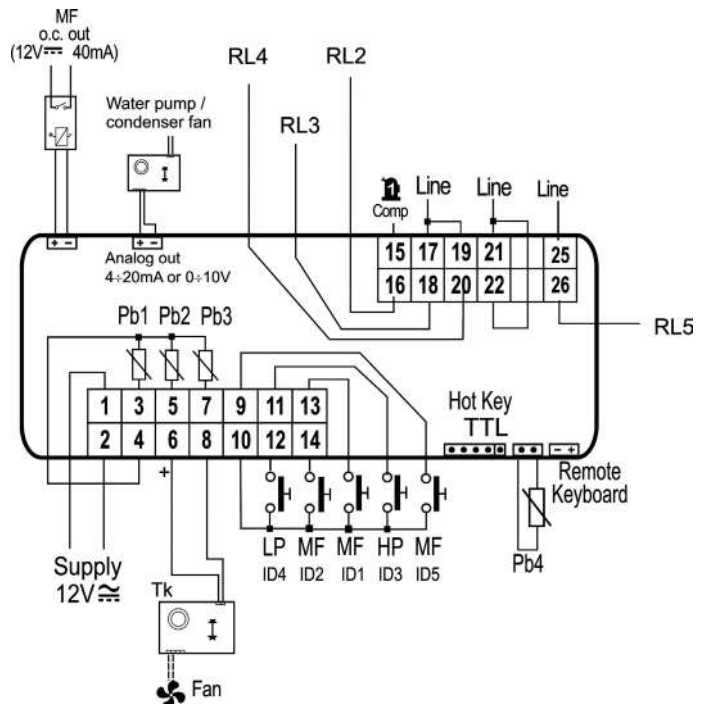

## 7. WIRING DIAGRAMS HUB RADIATOR MINI

### 7.1 KEY OF WIRING DIAGRAMS HUB RADIATOR MINI

#### LEGEND

<b>M1</b>	Booster terminal block
<b>Pb1</b>	technical water probe
<b>Pb3</b>	Booster battery probe
<b>Pb4</b>	electrical resistance probe
<b>St</b>	compressor thermal probe
<b>Tr</b>	transformer 230V - 12V
<b>R1</b>	health care priority management relay
<b>RD</b>	diverter relay
<b>RP</b>	system pump relay
<b>RT</b>	voltage mounting relay (3)
<b>TA</b>	room thermostat
<b>R</b>	electrical resistance 1500W (4)
<b>CD</b>	digital controller DIXELL
<b>VD</b>	diverter valve (2)
<b>P</b>	system pump
<b>Cr</b>	remote control (1)
<b>TM</b>	minimum thermostat
<b>MT</b>	magnetothermic 20A curve C
<b>IR</b>	electrical resistance switch
<b>DR</b>	electrical resistance diverter

#### Cr (1)



**Remote Command  
P 15**

#### R (4)



**Resistance relay  
Electric**

*Before making connections  
make sure you have  
correctly sized  
the section of the power cables  
based on the actual distance  
from the counter.  
Always provide for a special one  
magnetothermic protection*

#### VD (2)



**Letter A**  
diverter valve  
powered flow  
towards the plant

**Letter B**  
diverter valve  
not powered  
health priority

**Letter AB**  
circulator side

#### RT (3)

**Relay setting**

**Voltage monitoring**

<input checked="" type="checkbox"/>	<b>U<sub>max</sub> 253 V</b>
<input checked="" type="checkbox"/>	<b>T 8 s</b>
<input checked="" type="checkbox"/>	<b>U<sub>min</sub> %80</b>

<input checked="" type="radio"/>	<input type="radio"/>	<b>OK</b>
<input checked="" type="radio"/>	<input checked="" type="radio"/>	<b>U &gt; U<sub>max</sub></b>
<input checked="" type="radio"/>	<input checked="" type="radio"/>	<b>U &lt; U<sub>min</sub></b>

**IR**  
switch  
resistance



**DR**  
diverter  
resistance



#### A) Heat pump only operation

The key on the left of the figure must be in the OFF position "0 key", in this way the electric resistance will never work

#### B) Resistance heat pump operation

To use the integration resistance just press the left button in the **ON** position "I key" and the one on the right in the **INTEGRATION** position "key II".

In this way, the control unit will decide when help is needed of the resistance that will work in conjunction with the heat pump. Resistance only operation.

To use only the resistor instead of the heat pump, just press the left button in the **ON** position "I button" and the right one in the **EMERGENCY** "button I" position.

7.2 WIRING DIAGRAM HUB RADIATOR MINI 6.0

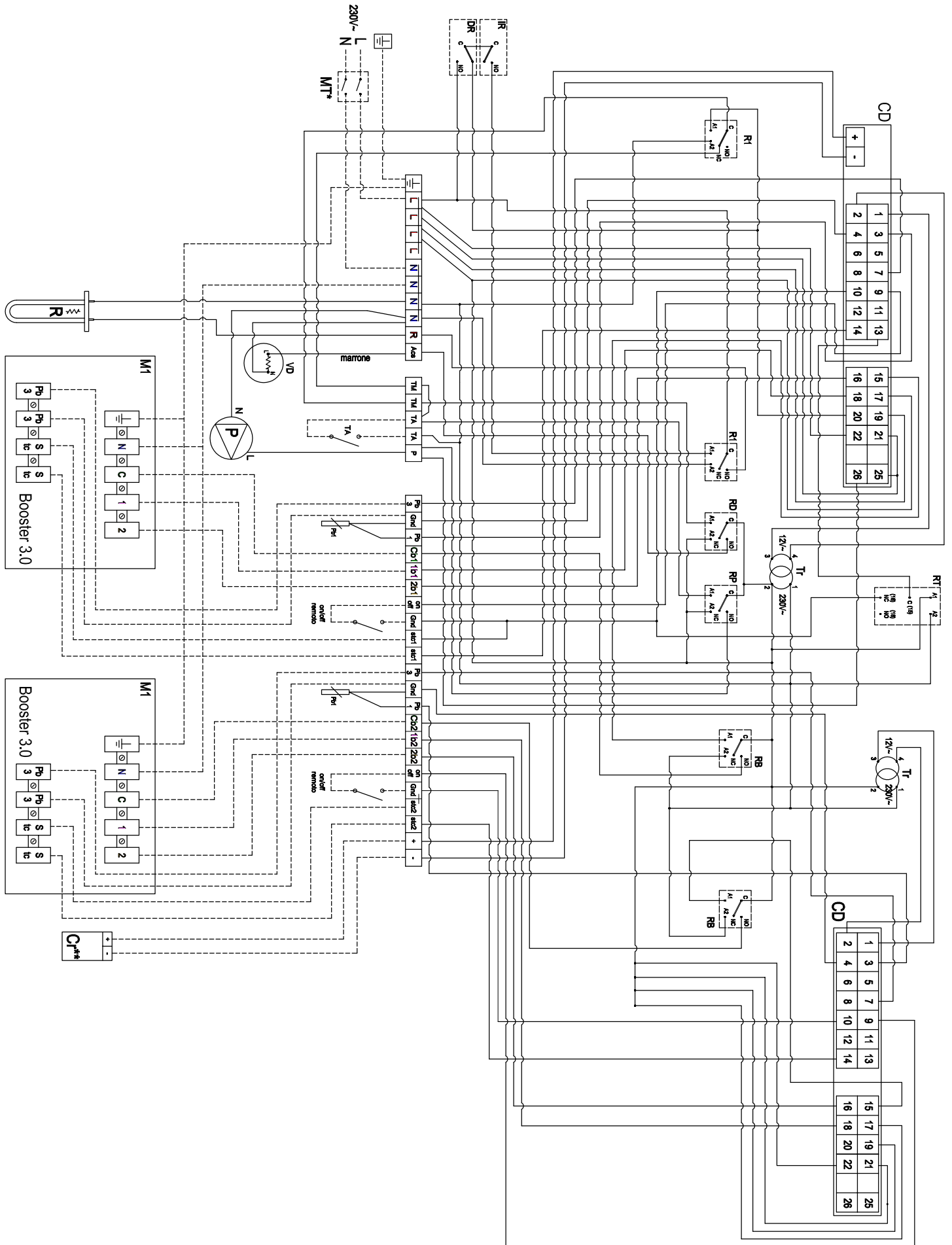

7.3 WIRING DIAGRAM HUB RADIATOR MINI 8.0

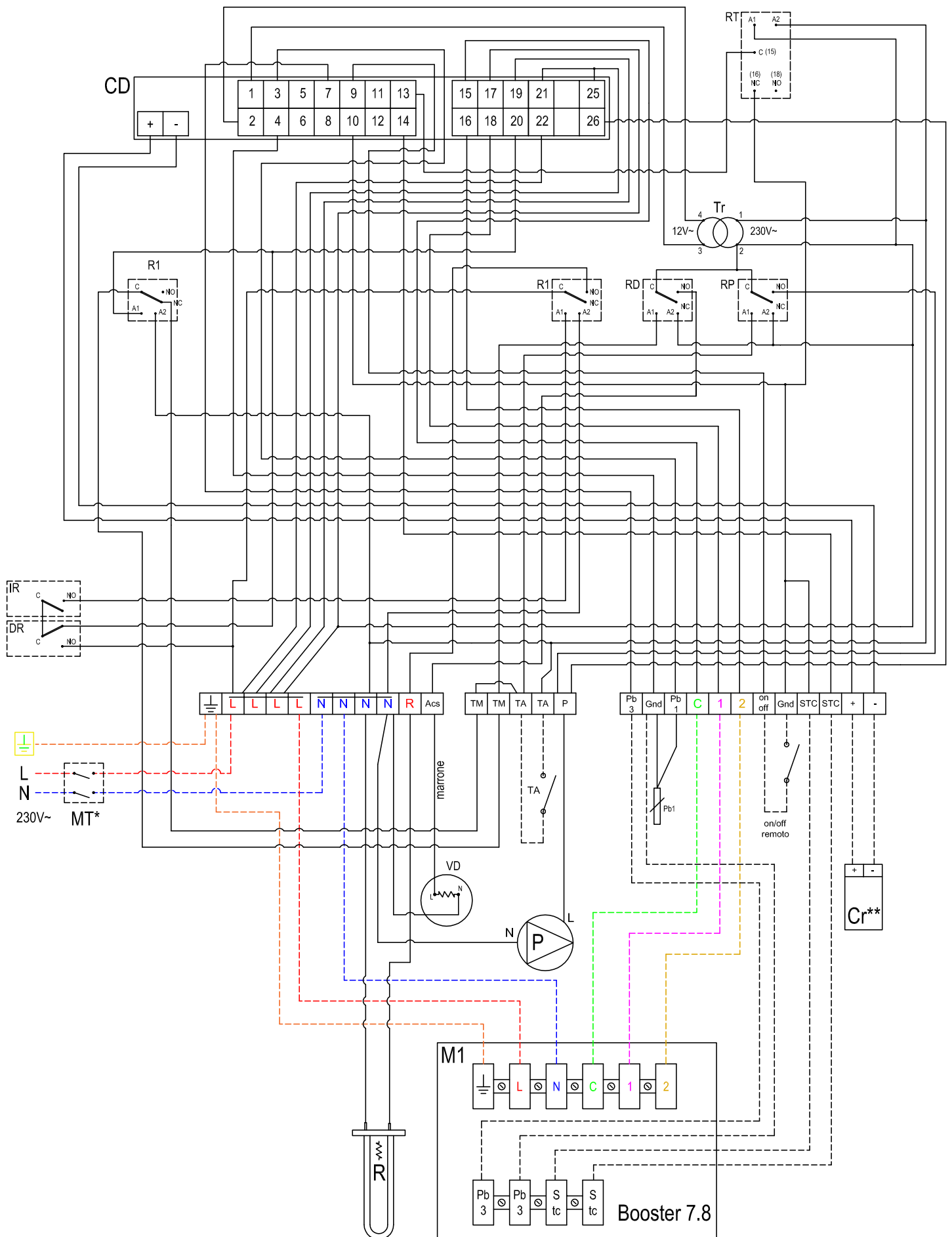

7.4 WIRING DIAGRAM HUB RADIATOR MINI 11.0

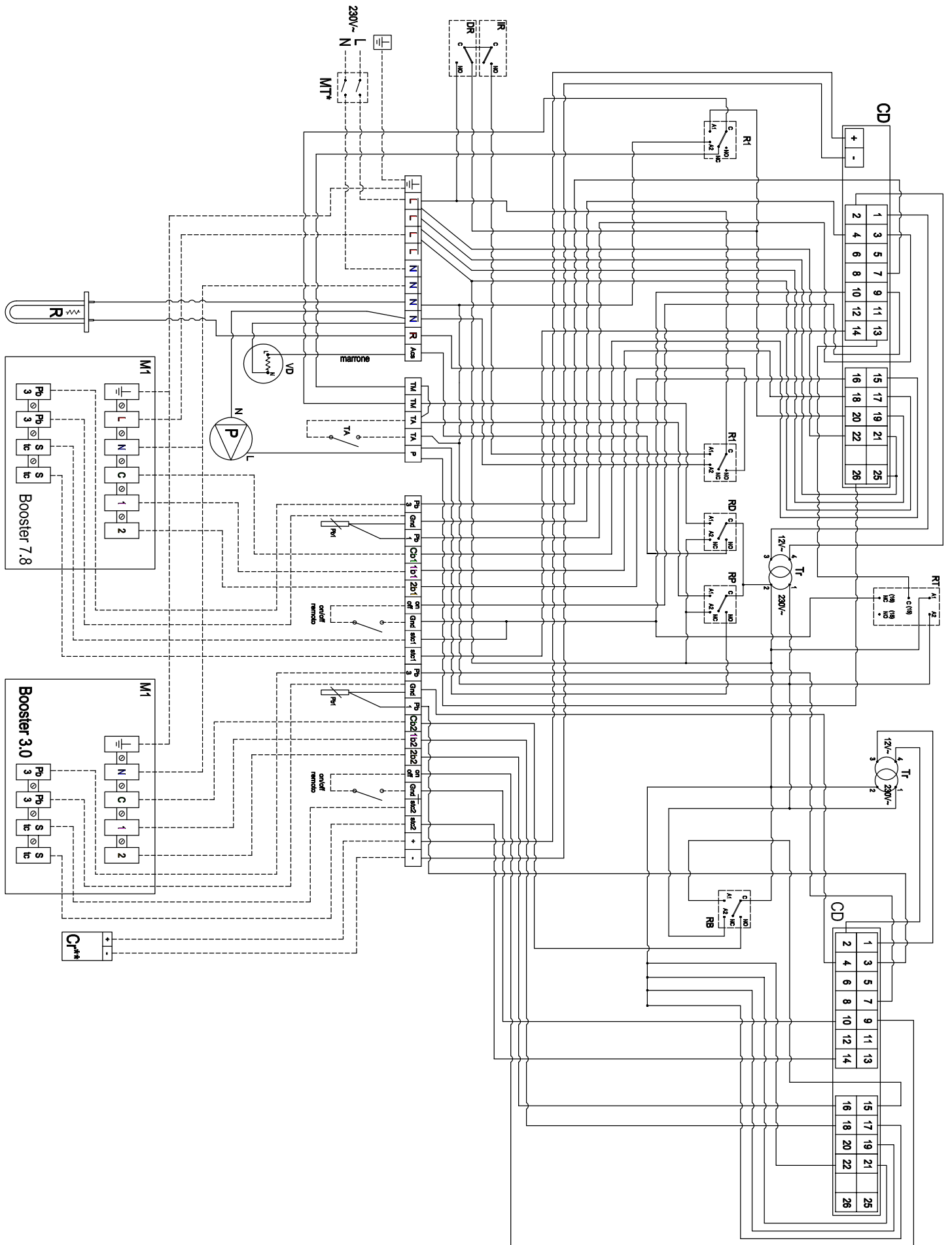

7.5 WIRING DIAGRAM HUB RADIATOR MINI 16.0

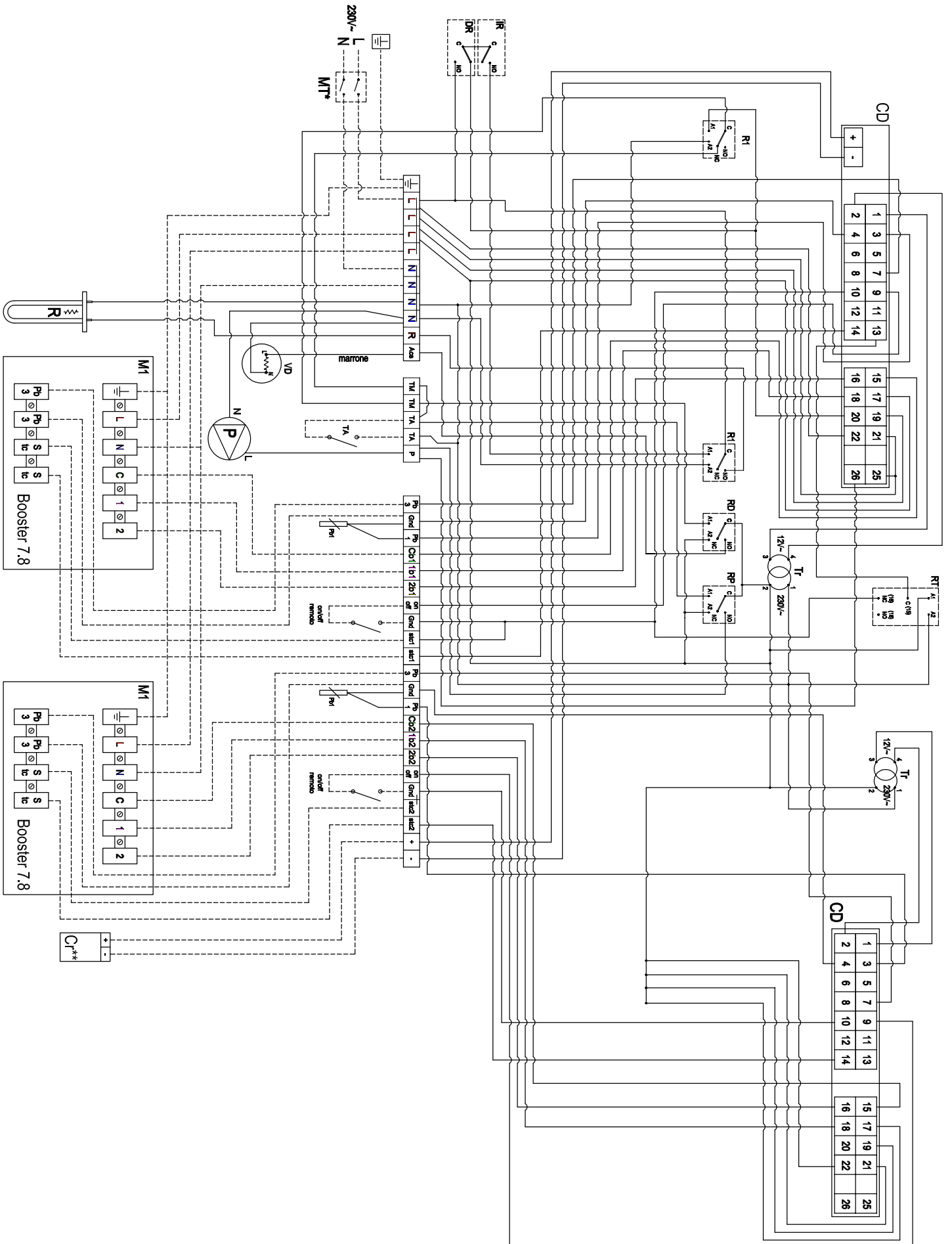

## 8. HYDRAULIC AND OPERATING DIAGRAMS HUB RADIATOR MINI

### 8.1 HYDRAULIC DIAGRAM APPLICATION EXAMPLE HUB RADIATOR MINI 8.0

- |   |   |
|---|---|
| 1 External moto-evaporator Booster HR 7.8 | 16 System delivery                        |
| 2 Indoor unit HUB RADIATOR MINI 70 liters | 17 System return                          |
| 3 8 liter expansion vessel                | 18 Water network inlet                    |
| 4 Electric command and control panel      | 19 Jolly air vent valve                   |
| 5 Inverter electronic circulator          | 20 Pressure gauge                         |
| 6 Softener                                | 21 System make-up cock                    |
| 7 "Y" filter                              | 22 Booster electronic control unit        |
| 8 Water meter counter                     | 23 Electric heater ON-OFF switch          |
| 9 Pressure reducer                        | 24 Programmer clock                       |
| 10 Sand trap filter                       | 25 Electric heater emergency switch       |
| 11 Magnetic dirt separator                | 26 Safety valve                           |
| 12 DHW mixing valve                       | 27 DHW priority diverter valve            |
| 13 System manifold                        | 28 System drain cock                      |
| 14 Domestic hot water delivery            | 29 Refrigeration line R410A 1/4 "(liquid) |
| 15 Domestic cold water delivery           | 30 5/8 "R410A refrigeration line (gas)    |

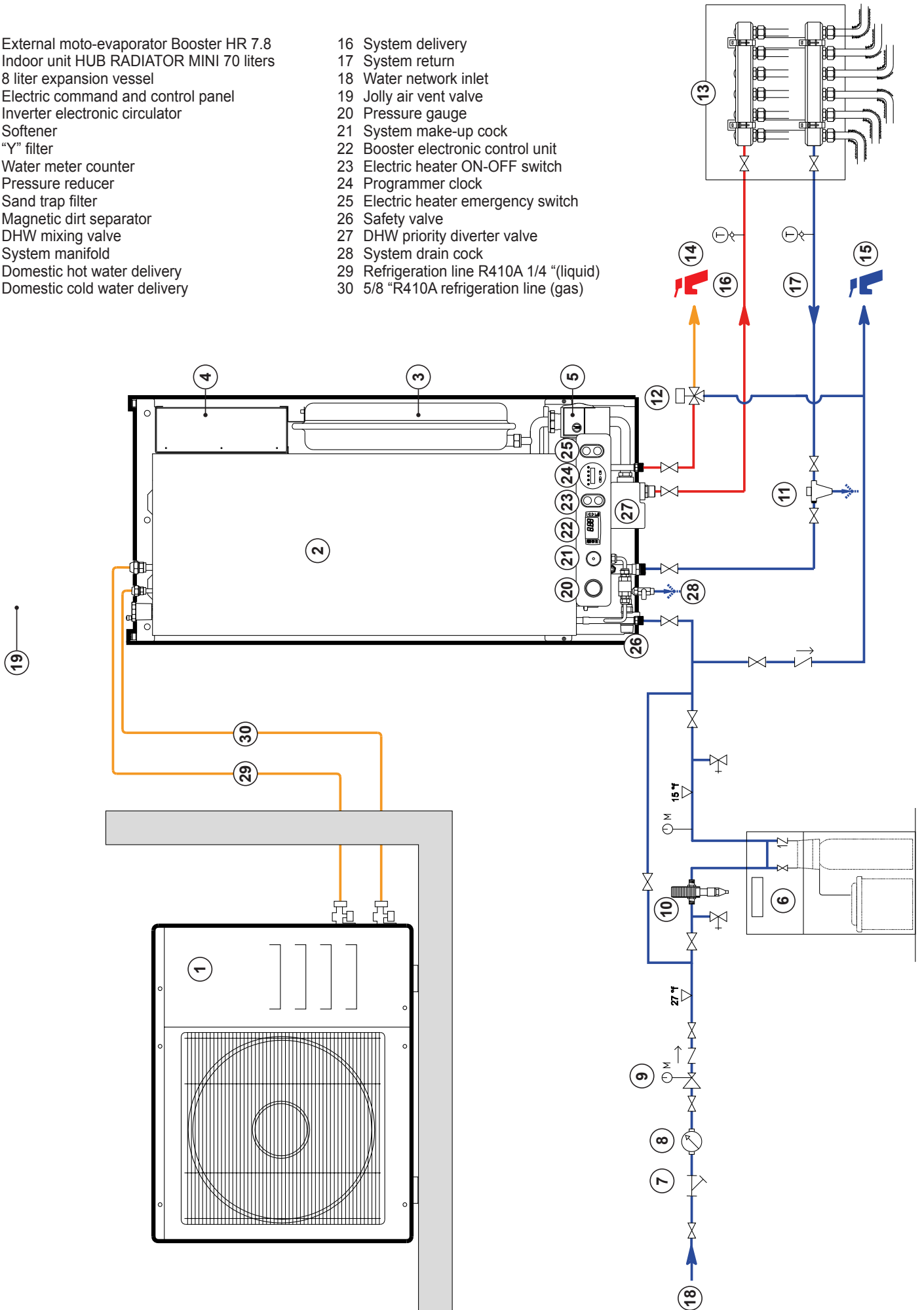

## 8.1 HYDRAULIC DIAGRAM APPLICATION EXAMPLE HUB RADIATOR MINI 16.0

- |   |   |
|---|---|
| 1 External moto-evaporator Booster HR 7.8 | 17 System return                          |
| 2 Indoor unit HUB RADIATOR MINI 70 liters | 18 Water mains inlet                      |
| 3 8 liter expansion vessel                | 19 Jolly air vent valve                   |
| 4 Electric command and control panel      | 20 Pressure gauge                         |
| 5 Inverter electronic circulator          | 21 System make-up cock                    |
| 6 Softener                                | 22 Booster electronic control units       |
| 7 "Y" filter                              | 23 Electric heater ON-OFF switch          |
| 8 Water meter counter                     | 24 Programmer clock                       |
| 9 Pressure reducer                        | 25 Electric heater emergency switch       |
| 10 Sand trap filter                       | 26 Safety valve                           |
| 11 Magnetic dirt separator                | 27 DHW priority diverter valve            |
| 12 DHW mixing valve                       | 28 System drain cock                      |
| 13 System manifold                        | 29 DHW circulation pump                   |
| 14 Domestic hot water delivery            | 30 Refrigeration line R410A 1/4 "(liquid) |
| 15 Domestic cold water delivery           | 31 5/8 "R410A refrigeration line (gas)    |
| 16 System delivery                        |   |

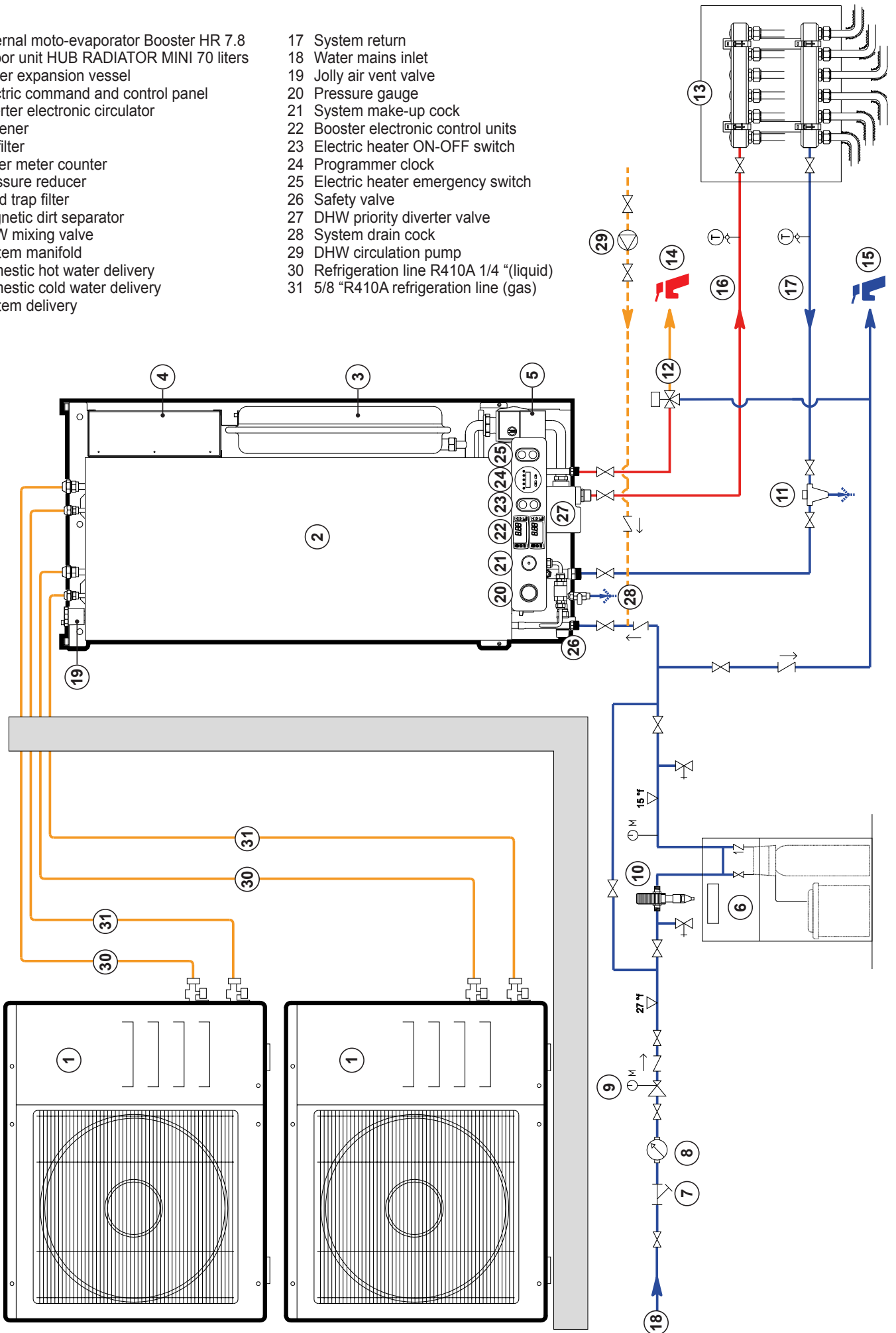



## 9. HUB RADIATOR MINI CIRCULATOR



the electronic circulator supplied as standard HUB RADIATOR MINI can power:

- the underfloor heating system;
- the wall heating system;
- the radiator system;
- the heating-only fan coil system.

In some cases HUB RADIATOR MINI can be connected simultaneously to two or more types of systems.

The power supply of the circulator has already been carried out by our technicians during the assembly phase and allows the circulator to work both when the room thermostat requires heat and when the flow switch indicates that a domestic hot water withdrawal is in progress.

In the case of a radiant floor system, the circulator will be controlled by the room thermostat and the water delivery temperature is regulated by a three-way mixing valve at a fixed point and the value can be modified to adapt it to the system design value. This valve must be purchased separately as an accessory.

A safety thermostat must be installed on the delivery pipe that blocks the operation of the pump, if the delivery temperature, for some reason, exceeds the threshold value, in order to avoid overheating of the floor and its excessive expansion.

The characteristics of the circulator are shown on page. 18, which shows the useful head of the system as a function of the water flow and the thermal power of the heating system. A water flow rate is normally considered such as to obtain a temperature delta between delivery and return of 10 ° C in nominal conditions.

## 10. DIVERTER VALVE HUB RADIATOR MINI



All the products of the HUB RADIATOR MINI series are equipped with a motorized diverter valve with spring return. The diverter valve is powered and automatically diverts to the system when the temperature of the technical storage exceeds 47 ° C (parameter AR21), vice versa below this temperature the system remains in sanitary priority, inhibiting the operation of the circulator even in conjunction with the consent of the room thermostat.

## 11. ELECTRIC RESISTANCE HUB RADIATOR MINI



All the products of the HUB RADIATOR MINI series are equipped with a 1500W single-phase electrical resistance. This resistor can be used both to replace the heat pump and to supplement it.

the type of operation can be selected using the buttons on the control plate of the external cover cabinet.

A) Heat pump only operation (fig. 11)

The key on the left of the figure must be in the OFF position “key 0”, in this way the electric resistance will never work

B) Resistance heat pump operation (fig. 11)

To use the integration resistance just press the left button in the ON position “button I” and the right one in the INTEGRATION position “button II”.

In this way, the control unit will decide when the help of the resistor is needed, which will work in conjunction with the heat pump.

Resistance only operation (fig. 11)

To use only the resistance to replace the heat pump, just press the left button in the ON position “button I” and the right one in the EMERGENCY position “button I”.



## 12. WARNINGS

### **12.1 QUALIFICATION OF THE INSTALLER**

**ATTENTION!** It is foreseen by the legislation in force on the matter (law 5 March 1990 n.46 and related Implementation Regulations) that the installation is carried out by an authorized company able to ensure, in addition to the correct implementation of the system, also the necessary checks before commissioning.

## 12.2 PRELIMINARY INFORMATION

Before starting the installation, it is necessary to make sure that the planning phases and obtaining any necessary authorizations have been completed (for example: local authorities - Municipality, etc.), in addition to the appropriate technical checks (for example: evaluation of acoustic impact).

It is recommended in order to rely on a qualified heating engineer who guarantees the correct execution of the aforementioned phases, whether they are optional or mandatory.

## 12.3 TRANSPORT AND HANDLING

The device is shipped on wooden pallets, with cardboard and plastic protections. The appliance can be handled by suitably equipped personnel and with equipment suitable for the weight of the product, such as a forklift or transpallet, taking care to distribute the weight on the supports, which is unbalanced towards the compressor (water connections side).

Any lifting by means of belts or ropes can be carried out by binding the ropes to two sturdy metal pipes inserted in the crossbars present under the base of the machine.

Ensure that the ropes are blocked at the points of anchorage to the pipes by means of suitable fasteners or safety pins; protect the contact points between the ropes and the appliance using cardboard or other suitable material.

Upon delivery, check that during transport no visible damage has occurred on the packaging and / or on the appliance. If damage is found, immediately file a formal complaint with the shipper. Do not install equipment damaged during transport.

**It is forbidden to dispose of the packaging parts in the environment, or leave them within the reach of children as they are a potential source of danger.**

## 12.4 USE OF THE INSTRUCTIONS

This manual is an integral part of the product and must be given to the owner of the appliance, so that he can keep it carefully for any future use or for consultation.

**ATTENTION! When installing or working on the appliance, observe all the instructions contained in this manual and anything else applicable to the product, according to national safety standards. Changes to connections of any kind and / or failure to comply with these instructions will result in the immediate forfeiture of the manufacturer's warranty and liability.**

## 12.5 GENERAL SYSTEM CHECKS

**ATTENTION! Before filling the system, make sure that the pipes do not contain foreign material, such as sand, slag, rust flakes and so on, which could damage the exchanger. It is good practice to wash the system, by-passing the unit, before filling it.**

Load the system, taking care to check the opening of the shut-off valves and the closure of the system drain cock.

### ATTENTION!

- **Connect the indoor unit first and then the outdoor unit, firmly fixing the pipes.**
- **Make sure that the drain is not loose.**
- **Make sure that the auxiliary lines are stay isolated.**
- **Make sure that the drain drains properly. Attach the drain to the other pipes.**
- **Do not allow the power cables to come into contact with pipes.**
- **Install zone motorized valves in the system to prevent the water contained in the accumulation not circulate freely when it is not necessary, that is when there is no consent from the thermoregulation.**

## 13. START-UP

### 13.1 FIRST START-UP MODE

In order to activate the warranty conditions provided for by the regulations in force, it is mandatory to request the first ignition service from a C.A.T. A2B Accorroni E.G. s.r.l. authorized by filling in the form shown.

The form must be sent by e-mail to [postvendita@accorroni.it](mailto:postvendita@accorroni.it)

### 13.2 FIRST START-UP CHECKS

Before proceeding with the commissioning of the device, it is necessary to make sure that:

- the safety conditions and all the provisions set out in this manual has been complied with;
- the fixing to the support surface is stable and the areas of respect are free from any obstacle or material that prevent easy accessibility to the device;
- the hydraulic and electrical connections, with particular attention to grounding, have been carried out correctly;
- interception, loading, unloading and venting devices of the plant are in the correct operating conditions and have been properly checked.

**ATTENTION! The start-up of the appliance, in conditions of non-compliance with the requirements of this manual and / or the regulations in force on safety and plant engineering, will result in the forfeiture of the warranty conditions.**

### 13.3 START-UP

The start-up of the device and the selection of the operating mode can be performed by acting directly on the microprocessor keyboard with the "SUN" button.

Press and hold for at least 2/3 seconds, when released, the LED indicating the sun will begin to flash (compressor count).

After a few minutes the LED will become steady, and the machine will start operating, heating the technical water of the indoor unit up to the SET-POINT temperature. At this point the machine enters full capacity and will carry out all the on and off cycles automatically and autonomously.

After starting the device, check the correct functioning of the system, paying particular attention to the following:

- the water pump must not emit abnormal noise, as this situation indicates that the air has not been purged correctly or that the water flow rate is not sufficient (possible obstructions, clogging or regulation of the devices on the system);
- the voltage measured in the power supply terminals must be included in the 210-240 Volt range for models with single phase power supply. Lower values indicate one voltage drop in the power line too high, with consequent possible damage to the compressor, which can also occur also for voltages greater than those indicated above;
- the temperature difference measured between the inlet and outlet of the device it must be between 3 ° C and 8 ° C; values less than 3 ° C indicate an excessive flow of water, vice versa the flow it will be too low with values greater than 8 ° C;
- if the above conditions do not come realized, turn off the machine and made corrective actions to allow the regular operation of the system.

## **14. REPAIR - COMPONENTS REPLACEMENT**

Specific technical expertise is required to work on the components listed below and / or to replace them, so it is recommended that you always contact an authorized Technical Assistance Center. For safety and quality purposes it is recommended to use original components and spare parts for replacements.

Always operate in conditions of maximum safety, in compliance with current regulations on the subject. Before any intervention on the appliance, disconnect the power supply by acting on the main switch and then on the disconnect on the machine.

For any operations of emptying and charging of refrigerant gas, it is recommended to use specific equipment for the recovery of the refrigerant, in order to protect the environment.

### **14.1 REFRIGERANT CIRCUIT**

For any reason it is necessary to repair the refrigerant circuit, with consequent contamination, as in the case of burning of the electrical windings of the compressor or failure of the circuit with complete emptying, the following must always be carried out:

- circuit cleaning;
- drying and high vacuum;
- leak test and charge recovery.

### **14.2 DRYING AND VACUUM OF THE SYSTEM**

Drying and high vacuum are necessary to evacuate the air, humidity, and all gases that may be in solution with the compressor oil.

If there is water in the liquid phase in the system, it is necessary to slightly heat the parts in which it is deposited, in order to favor evaporation.

The capacity of the high vacuum pump must be adequate for the system in which it is to be operated; the use of a pump with a flow rate of at least 90 liters / minute is recommended.

The degree of vacuum must be checked with a suitable vacuum gauge for medium vacuum, possibly electronic, with resolution in microns of the scale.

- Carrying out a high vacuum:
  - connect the pump to the system by means of pipes, connections from 1/4 SAE female swivel, to the pressure points shown on the suction and delivery connections in the compressor;
  - connect a vacuum gauge
  - vacuum up to a value of at least 350, 500 microns for a minimum time of at least 30 minutes.

### **14.3 CLEANING THE CIRCUIT**

**ATTENTION!** If the motor burns, with perforation of the windings, it is necessary to carefully clean the refrigerant circuit to avoid subsequent burns or breakdowns.

Cleaning operations have the purpose of eliminating all carbon or other solid state deposits and, according to the method used, all contaminants that have been introduced for cleaning the circuit or as a result of the operations performed must be eliminated.

**ATTENTION!** Do not inhale refrigerant vapors from burnt compressors, as toxic products may be present. Completely avoid contact with the skin of the residual oil from the burnt compressor.

### **14.4 REFRIGERANT CHARGE**

**ATTENTION!** The refrigerant gas in the liquid state must not be charged in suction on the compressor as this condition causes damage to the compressor.

The operations to be carried out are as follows:

- connect the cylinder (or the charging cylinder) to the system by means of pipes and 1/4 SAE female swiveling connections to the pressure point on the liquid side of the air / gas exchangers refrigerant;
- insert refrigerant in the liquid state:
  - a) until the necessary office is reached;
  - b) until the balance of pressures between cylinder and refrigerant circuit;
- start the appliance and, if necessary, insert the refrigerant remaining until the prescribed values are reached. The charge setup operation must be done using the suction socket of the compressor, by inserting the liquid refrigerant gradually;
- check the refrigerant charge.

**ATTENTION!** Make sure that the instruments used are in good condition and properly calibrated.

### **14.5 CHECK OF OVERHEATING**

- start the appliance;
- insert into the pressure point, positioned in the large tube near the compressor, the low pressure gauge for the pressure measurement;
- wait for the values to stabilize for about 20 minutes;
- measure the temperature value on the large tube (phase steam), near the pressure point using a special contact probe;
- read the temperature value in the pressure gauge, in correspondence with the detected pressure value.

The temperature read on the thermometer must be greater than the temperature read on the pressure gauge by a value between 3 °C and 8 °C for operation in cooling mode, between 1 °C and 5 °C for operation in heating mode.

## **15. DIGITAL WEEKLY TIME PROGRAMMER KIT** **INSTRUCTIONS**

### **15.1 DESCRIPTION**

The programmer is equipped inside with a rechargeable lithium battery that allows it to keep time and programs for about 1 month, even without mains power supply.

During normal operation, the display shows the day of the week and the current time, as well as the operating status in which the presence of a light bulb symbol indicates that the appliance is on.

### **15.2 OPERATING INSTRUCTIONS**

The functions of the keys, with reference to fig. 14, are the following:

1) Time setting:

Press the clock symbol at the same time as the D + symbol to set the day of the week. To set the time, press the clock button at the same time as H +.

To set the minute, press clock at the same time as M +.

2) Gear / programming switch:

Press the "MANUAL" button to switch between the "ON" "AUTO" and "OFF" position.

3) "P" key for selecting the on / off programs.

4) "H +" key for advancement and hour selection.

5) "M +" button for advancing and selecting minutes.

6) "D +" button for advancing and selecting days of the week.

7) Key  to change the time and day of the week and to return to the current time when in "PROGRAMMING" mode.

### **15.3 INSTRUCTIONS FOR USE**

#### **SETTING THE CURRENT DAY AND TIME**

To allow the programmer to function correctly, it is necessary to set the current day and time by acting as follows:

- to set the correct day, press simultaneously the clock symbol and the D + symbol
- to set the correct time, press the clock symbol and the H + symbol
- to set the correct minute press simultaneously the clock symbol and the M + symbol

### **15.4 PROGRAMMING**

16 programs are available, of which 16 are for switching on and 16 for switching off

**ATTENTION! In all cases described below in which the programmer gives consent to start, the actual operation of the radiator is however also affected by the adjustment of the room thermostat located on the control panel of the radiator itself.**

To facilitate programming, if identical operating times are to be adopted for different days of the week, some combinations of days are available for repeating the set program, according to the following scheme:

- a different program for each day of the week (the day to be programmed appears highlighted on the mo-tu-we-th-fr-sa display.)
- the same program for the days from Monday to Friday
- the same program for the weekend on Saturdays and Sunday
- the same program for the days from Monday to Saturday
- the same program for all days of the week

To program the radiator operating intervals, proceed as follows:

- by pressing the P key, 1 on appears on the display;
- by pressing key D + you can choose the day of activation;

- to set the activation time, press the H + button;
  - to set the activation minute, press the M + key;
  - by pressing the P key again, 1 off appears on the display;
  - by pressing key D + you can choose the day of deactivation;
  - to set the deactivation time, press the H + button
  - to set the deactivation minute, press the M + key
- It is possible to set up to 16 daily switching on and off by repeating the settings from point "a" to point "h". If the keys are not operated within 10 seconds, the display returns to the main screen.

### **15.5 MANUAL OPERATION**

Using simple commands it is possible, without modifying the programming, to start the radiator when the program itself foresees the off status or vice versa, proceeding as follows:

By pressing the manual button you can switch the setting off, auto, and on (manual operation).



Fig.14

**16. Checks for the HUB RADIATOR first start-up request**



Installer \_\_\_\_\_

Designer \_\_\_\_\_

**Plant location**

Street \_\_\_\_\_ N° \_\_\_\_\_

City \_\_\_\_\_ CAP \_\_\_\_\_ Province \_\_\_\_\_

Installed System Mode \_\_\_\_\_ U.I. serial number \_\_\_\_\_

Installation date \_\_\_\_\_ EU freshmen \_\_\_\_\_

**Plant type**

- Radiators  Summer cooling  Fan-Coil   
 DHW production  Radiant panels  Heating

**Outdoor unit and indoor unit checklist**

**YES NO VALUE**

The outdoor unit is located outside the building			
The outdoor unit is perfectly level on both axes			
Presence of anti-vibration mounts between the outdoor unit and the ground or shelf			
Check the safety distances indicated in the manual			
Distance between indoor and outdoor unit (max 15m) attached <b>A</b>			
Difference in height between indoor and outdoor unit (max 5 m) attached <b>A</b>			
The pipes of the refrigeration lines (1/4 “- 3/8”) for HR 3.0 or (1/4 “- 5/8”) for HR 7.8			
Folder tightness control			
Check for any crushing of copper pipes			
Control of the insulation of the refrigeration lines			
The refrigeration lines were pressed with nitrogen at 40 bar for at least 12 h			
The refrigeration system was put under vacuum			
Condensate drain connection with suitable slope			
The distances shown in the attachment have been respected <b>B</b>			

**Electrical wiring check list**

Adequate magnetothermic switch dedicated to the indoor unit			
Distance between electrical contactor and indoor unit			
Cable section Appropriate electric power supply			
Connecting the room thermostat			
The correct tightening of the electrical connections has been carried out			
Electric power cable section between internal and external			
Communication cable of the indoor and outdoor unit (3x1.0 mm <sup>2</sup> ) (contacts C, 1.2)			
Signal cable between indoor and outdoor (4x0.75mm <sup>2</sup> for PB3 and STC)			
A suitable grounding has been performed			

**Indoor unit checklist**

	YES	NO	VALUE
All safety conditions have been respected			
The unit is fixed to the support surface			
The correct sizing of the expansion vessel has been checked ( <i>indicate the volume</i> )			
Unit installed locally protected from atmospheric agents			
There is a shut-off valve in the thermal circuit			
The hydraulic circuit has been washed or cleaned ( <i>only in case of replacement of the old generator</i> )			
The hydraulic circuit has been charged and bled			
There is a magnetic dirt separator at the system return			
Insulated system delivery and return pipes			
Realization of the connection between the safety valve and the water drain			
Air vent valves have been installed at the highest points of the system			
There is a hydraulic circuit breaker			
There is a softener			
There is a pressure reducer			

**Note:**

---



---



---



---



---



---



---



---

Beware of the failure to carry out the first start-up for reasons not dependent on the unit will involve a second visit which will be directly charged to you by the Assistance Center Local technique.

Signature of the installer \_\_\_\_\_ Date \_\_\_\_\_

# Attached A

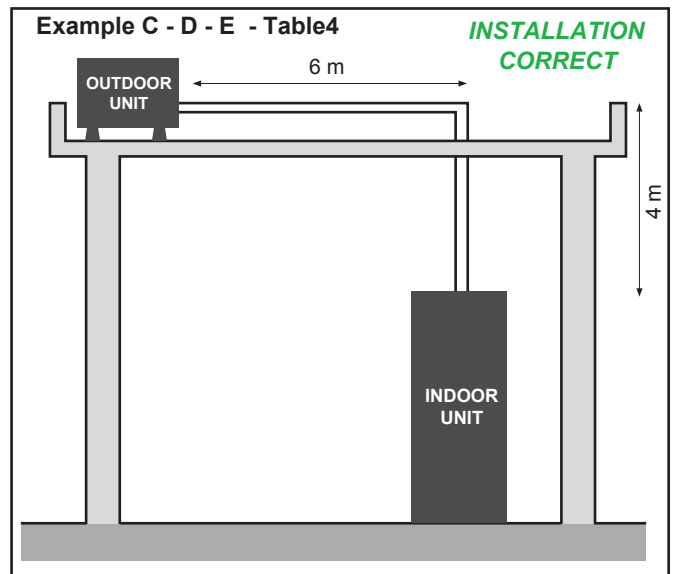
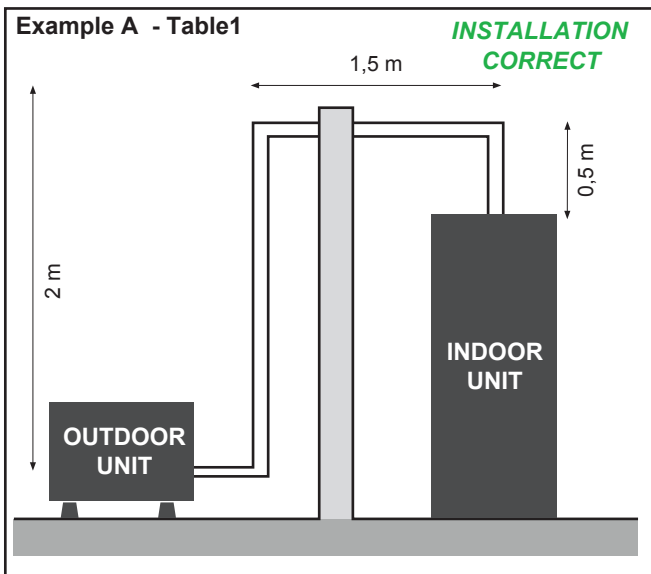
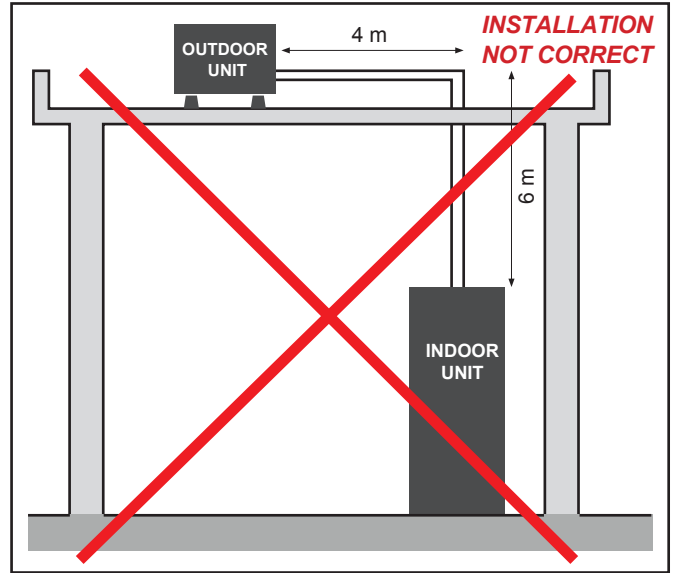
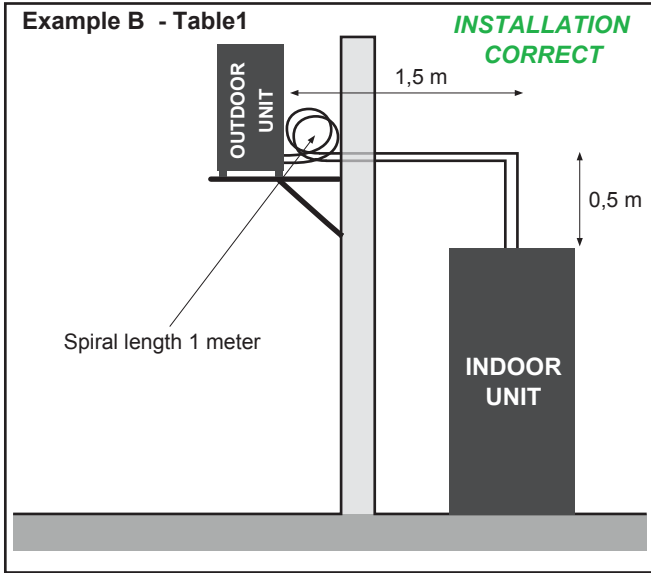
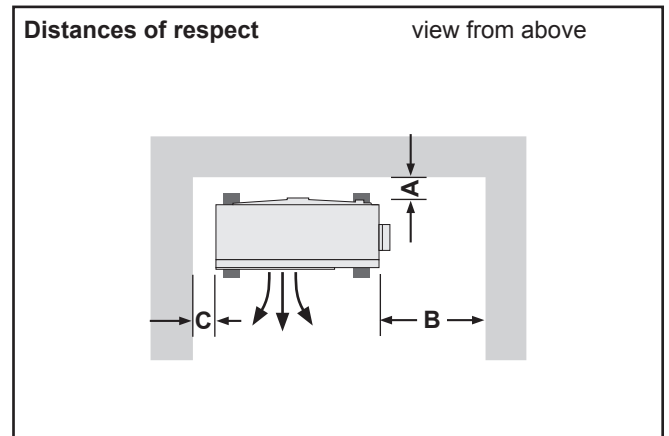
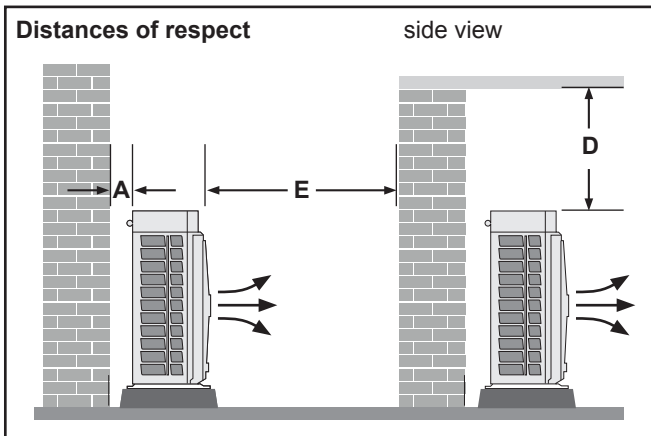

**Table 1 - Permissible distances INDOOR UNIT - OUTDOOR UNIT**

Models	HR 3.0	HR 7.8	HR 9.0 INVERTER
<b>A</b> Maximum length allowed without adding refrigerant	5*m	5*m	5*m
<b>B</b> Minimum allowed length of refrigerant gas	3*m	3*m	3*m
<b>C</b> Maximum length of refrigerant gas piping	15*m	15*m	15*m
<b>D</b> Maximum admissible height difference between O.U and I.U.	5*m	5*m	5*m
<b>E</b> Additional refrigerant quantity over 5 meters	20*g/m	20*g/m	20*g/m

Failure to comply with this application will result in the **non-ignition by the authorized assistance**

# Attached B



**LEGEND: (A = 15 cm) - (B = 50 cm) - (C = 15 cm) - (D = 60 cm) - (E = 100 cm)**

**17. FIRST START-UP BOARD PATENTED SYSTEM A PdC HUB RADIATOR (attached 1)**



**A2B ACCORRONI E.G. s.r.l.**

MR. \ COMPANY \_\_\_\_\_ Cod. Fisc. - P. Iva \_\_\_\_\_

**TECHNICAL ASSISTANCE DATA**

CITY \_\_\_\_\_ STREET \_\_\_\_\_

PHONE \_\_\_\_\_ EMAIL ADDRESS \_\_\_\_\_

**SYSTEM DATA**

CITY \_\_\_\_\_ STREET \_\_\_\_\_

INSTALLATION DATE \_\_\_\_\_ TEST DATE \_\_\_\_\_

TYPE:

- HUB RADIATOR MINI                       HUB RADIATOR MINI XL                       HUB RADIATOR PLUS                       HUB RADIATOR DHP
- HUB RADIATOR PACK C                       HUB RADIATOR PACK CF                       HUB RADIATOR AP                       SUPER HUB RADIATOR
- SUPER HUB RADIATOR TOP                       POWER UNIT                       GRUPPI FRIGORIFERI VT                       HUB RADIATOR BLACK

OUTDOOR UNIT:

MODEL	SERIAL NUMBER	PIPES DIAMETER	MODEL	SERIAL NUMBER
_____	_____	_____	_____	_____
_____	_____	_____	_____	_____
_____	_____	_____	_____	_____

**POSITIONING THE OUTDOOR UNIT**

- TO THE GROUND     WALL     A WINDOW     ON BRACKETS     ANTI-VIBRATION
- SHELVES     ROOF     OTHER     ON BASES     SUSPENSION     RAILING

INSTALLATION WITH SCAFFOLDING     YES     NO    METERS \_\_\_\_\_    NECESSARY FOR ORDINARY MAINTENANCE     YES     NO  
NECESSARY FOR ORDINARY MAINTENANCE     YES     NO

AGG GAS     YES     NO    QUANTITY \_\_\_\_\_

**DIFFERENCE IN HEIGHT BETWEEN BOOSTER AND ACCUMULATION**

INDOOR UNIT HIGHER THAN THE OUTDOOR UNIT        SIPHON     YES     NO    WHERE IS IT \_\_\_\_\_    ALTITUDE METERS \_\_\_\_\_  
OUTDOOR UNIT HIGHER THAN THE INDOOR UNIT        SIPHON     YES     NO    WHERE IS IT \_\_\_\_\_    ALTITUDE METERS \_\_\_\_\_

**DISTANCE BETWEEN BOOSTER AND ACCUMULATION**

BOOSTER 1 \_\_\_\_\_                      BOOSTER 4 \_\_\_\_\_                      BOOSTER 7 \_\_\_\_\_  
BOOSTER 2 \_\_\_\_\_                      BOOSTER 5 \_\_\_\_\_                      BOOSTER 8 \_\_\_\_\_  
BOOSTER 3 \_\_\_\_\_                      BOOSTER 6 \_\_\_\_\_                      BOOSTER 9 \_\_\_\_\_

**WELDINGS (BY THE INSTALLER)**

WELDINGS ON:     INTERNAL MACHINE                       EXTERNAL MACHINE                       REFRIGERATOR LINE

SPECIFY WHERE THE WELDINGS WERE NEEDED \_\_\_\_\_



## PROVE EFFETTUATE

VUOTO IMPIANTO     SI     NO    MESSA A TERRA IMPIANTO APPARTAM. PRESENTE  
VERIFICA PERDITE     SI     NO    MESSA IN PRESSIONE CON AZOTO     SI     NO  
PROVE SINGOLE UNITÀ     SI     NO    VERIFICA RIEMPIMENTO ACCUMULO     SI     NO  
CABLAGGI CORRETTI     SI     NO    VERIFICA GRUPPO REINTEGRO     SI     NO

MISURA TENSIONE DI RETE VALORE VOLT\*\* \_\_\_\_\_

**\*\*ATTENZIONE! sotto i 215 V non accendere la macchina**

## MISURARE LA TEMPERATURA CON TUTTI I BOOSTER IN FUNZIONE ED EVENTUALE IMPIANTO FOTOVOLTAICO SPENTO

### FUNZIONAMENTO IN POMPA DI CALORE BOOSTER 1

TEMPERATURA DI EVAPORAZIONE U.E. °C (Pb3) .... \_\_\_\_\_

TEMPERATURA ACQUA TECNICA °C (Pb1) ..... \_\_\_\_\_

TEMPERATURA DI INIZIO CONDENSAZIONE °C\* ..... \_\_\_\_\_

PRESSIONE DI INIZIO CONDENSAZIONE (Bar) ..... \_\_\_\_\_

CORRENTE ASSORBITA COMPRESSORE (A) ..... \_\_\_\_\_

**NB**

**Attendere che la temperatura dell'acqua tecnica arrivi ad almeno 50 °C prima di effettuare le misurazioni**

\***misurare la temperatura** direttamente sul tubo di rame che esce dalla parte superiore del compressore a circa 8 cm di distanza dalla calotta

### FUNZIONAMENTO IN POMPA DI CALORE BOOSTER 2

TEMPERATURA DI EVAPORAZIONE U.E. °C (Pb3) .... \_\_\_\_\_

TEMPERATURA ACQUA TECNICA °C (Pb1) ..... \_\_\_\_\_

TEMPERATURA DI INIZIO CONDENSAZIONE °C\* ..... \_\_\_\_\_

PRESSIONE DI INIZIO CONDENSAZIONE (Bar) ..... \_\_\_\_\_

CORRENTE ASSORBITA COMPRESSORE (A) ..... \_\_\_\_\_

**NB**

**Attendere che la temperatura dell'acqua tecnica arrivi ad almeno 50 °C prima di effettuare le misurazioni**

\***misurare la temperatura** direttamente sul tubo di rame che esce dalla parte superiore del compressore a circa 8 cm di distanza dalla calotta

### FUNZIONAMENTO IN POMPA DI CALORE BOOSTER 3

TEMPERATURA DI EVAPORAZIONE U.E. °C (Pb3) .... \_\_\_\_\_

TEMPERATURA ACQUA TECNICA °C (Pb1) ..... \_\_\_\_\_

TEMPERATURA DI INIZIO CONDENSAZIONE °C\* ..... \_\_\_\_\_

PRESSIONE DI INIZIO CONDENSAZIONE (Bar) ..... \_\_\_\_\_

CORRENTE ASSORBITA COMPRESSORE (A) ..... \_\_\_\_\_

**NB**

**Attendere che la temperatura dell'acqua tecnica arrivi ad almeno 50 °C prima di effettuare le misurazioni**

\***misurare la temperatura** direttamente sul tubo di rame che esce dalla parte superiore del compressore a circa 8 cm di distanza dalla calotta

### FUNZIONAMENTO IN POMPA DI CALORE BOOSTER 4

TEMPERATURA DI EVAPORAZIONE U.E. °C (Pb3) .... \_\_\_\_\_

TEMPERATURA ACQUA TECNICA °C (Pb1) ..... \_\_\_\_\_

TEMPERATURA DI INIZIO CONDENSAZIONE °C\* ..... \_\_\_\_\_

PRESSIONE DI INIZIO CONDENSAZIONE (Bar) ..... \_\_\_\_\_

CORRENTE ASSORBITA COMPRESSORE (A) ..... \_\_\_\_\_

**NB**

**Attendere che la temperatura dell'acqua tecnica arrivi ad almeno 50 °C prima di effettuare le misurazioni**

\***misurare la temperatura** direttamente sul tubo di rame che esce dalla parte superiore del compressore a circa 8 cm di distanza dalla calotta

### FUNZIONAMENTO IN POMPA DI CALORE BOOSTER 5

TEMPERATURA DI EVAPORAZIONE U.E. °C (Pb3) .... \_\_\_\_\_

TEMPERATURA ACQUA TECNICA °C (Pb1) ..... \_\_\_\_\_

TEMPERATURA DI INIZIO CONDENSAZIONE °C\* ..... \_\_\_\_\_

PRESSIONE DI INIZIO CONDENSAZIONE (Bar) ..... \_\_\_\_\_

CORRENTE ASSORBITA COMPRESSORE (A) ..... \_\_\_\_\_

**NB**

**Attendere che la temperatura dell'acqua tecnica arrivi ad almeno 50 °C prima di effettuare le misurazioni**

\***misurare la temperatura** direttamente sul tubo di rame che esce dalla parte superiore del compressore a circa 8 cm di distanza dalla calotta

**TESTS CARRIED OUT**

- SYSTEM VACUUM       YES  NO                      EARTHING HOUSE SYSTEM PRESENT
- CHECK FOR LEAKS     YES  NO                      PRESSURE WITH NITROGEN             YES  NO
- SINGLE UNIT TESTS     YES  NO                      ACCUMULATION FILLING CHECK       YES  NO
- CORRECT WIRING       YES  NO                      CHECK REINFORCEMENT GROUP       YES  NO

MEASUREMENT OF MAINS VOLTAGE VALUE VOLT\*\* \_\_\_\_\_

**\*\*ATTENTION! below 215 V do not turn on the machine**

**MEASURE THE TEMPERATURE WITH ALL BOOSTERS IN OPERATION AND ANY PHOTOVOLTAIC SYSTEM OFF**

**OPERATION IN BOOSTER HEAT PUMP 1**

- EVAPORATION TEMPERATURE O.U. °C (Pb3) .....
- TECHNICAL WATER TEMPERATURE °C (Pb1).....
- CONDENSATION START TEMPERTATURE °C\* .....
- CONDENSATION START PRESSURE (Bar) .....
- COMPRESSOR ABSORBED CURRENT (A) .....

**ATTENTION**

**Wait for the technical water temperature reaches at least 50 °C before taking measurements**

\* **measure the temperature** directly on the copper pipe that comes out from the top of the compressor about 8 cm away from the hood

**OPERATION IN BOOSTER HEAT PUMP 2**

- EVAPORATION TEMPERATURE O.U. °C (Pb3) .....
- TECHNICAL WATER TEMPERATURE °C (Pb1).....
- CONDENSATION START TEMPERTATURE °C\* .....
- CONDENSATION START PRESSURE (Bar) .....
- COMPRESSOR ABSORBED CURRENT (A) .....

**ATTENTION**

**Wait for the technical water temperature reaches at least 50 °C before taking measurements**

\* **measure the temperature** directly on the copper pipe that comes out from the top of the compressor about 8 cm away from the hood

**OPERATION IN BOOSTER HEAT PUMP 3**

- EVAPORATION TEMPERATURE O.U. °C (Pb3) .....
- TECHNICAL WATER TEMPERATURE °C (Pb1).....
- CONDENSATION START TEMPERTATURE °C\* .....
- CONDENSATION START PRESSURE (Bar) .....
- COMPRESSOR ABSORBED CURRENT (A) .....

**ATTENTION**

**Wait for the technical water temperature reaches at least 50 °C before taking measurements**

\* **measure the temperature** directly on the copper pipe that comes out from the top of the compressor about 8 cm away from the hood

**OPERATION IN BOOSTER HEAT PUMP 4**

- EVAPORATION TEMPERATURE O.U. °C (Pb3) .....
- TECHNICAL WATER TEMPERATURE °C (Pb1).....
- CONDENSATION START TEMPERTATURE °C\* .....
- CONDENSATION START PRESSURE (Bar) .....
- COMPRESSOR ABSORBED CURRENT (A) .....

**ATTENTION**

**Wait for the technical water temperature reaches at least 50 °C before taking measurements**

\* **measure the temperature** directly on the copper pipe that comes out from the top of the compressor about 8 cm away from the hood

**OPERATION IN BOOSTER HEAT PUMP 5**

- EVAPORATION TEMPERATURE O.U. °C (Pb3) .....
- TECHNICAL WATER TEMPERATURE °C (Pb1).....
- .....

**ATTENTION**

.....

**OPERATION IN BOOSTER HEAT PUMP 6 (HUB RADIATOR DHP - HUB RADIATOR TOP - GRUPPI FRIGORIFERI VT)**

EVAPORATION TEMPERATURE O.U. °C (Pb3) .....

TECHNICAL WATER TEMPERATURE °C (Pb1) .....

CONDENSATION START TEMPERTATURE °C\* .....

CONDENSATION START PRESSURE (Bar) .....

COMPRESSOR ABSORBED CURRENT (A) .....

**ATTENTION**

**Wait for the technical water temperature reaches at least 50 °C before taking measurements**

\* **measure the temperature** directly on the copper pipe that comes out from the top of the compressor about 8 cm away from the hood

**NOTE** \_\_\_\_\_  
\_\_\_\_\_  
\_\_\_\_\_  
\_\_\_\_\_

**N.B. INSTALLATION CARRIED OUT AS AGREED WITH THE CUSTOMER**

**INSTALLER**

SIGNATURE

**TECHNICAL ASSISTANCE**

SIGNATURE

**CUSTOMER**

SIGNATURE

\_\_\_\_\_

\_\_\_\_\_

\_\_\_\_\_



# Condizioni generali di garanzia A2B ACCORRONI E.G.

## DISPOSIZIONI GENERALI

### Premessa:

Per "Prodotto" da qui in avanti e per l'intero documento, si intende e si deve fare esclusivo riferimento al prodotto a marchio **A2B ACCORRONI E.G.**.

Per "Acquirente" da qui in avanti e per l'intero di documento, si intende e si deve far riferimento alla persona fisica o giuridica che ha acquistato il Prodotto, indipendentemente se il venditore sia **A2B ACCORRONI E.G.** o altro soggetto commercializzante i Prodotti a marchio **A2B ACCORRONI E.G.**.

- La presente garanzia relativa ai Prodotti a marchio **A2B ACCORRONI E.G.** è soggetta alla normativa comunitaria vigente 99/44/CE, alla legislazione nazionale DL 24/02 e DL 206/2005 applicabili ai beni di consumo;
- La presente garanzia è fornita esclusivamente per i Prodotti in oggetto installati in Italia, RSM e Città del Vaticano;
- La presente garanzia viene rilasciata sui Prodotti in oggetto e ha validità di ventiquattro (24) mesi decorrenti dalla data di acquisto del Prodotto (data documento fiscale rilasciato all'atto dell'acquisto) a cui si riferisce qualora l'acquirente lo acquisti per fini estranei alla propria attività imprenditoriale, commerciale e professionale ("Il Consumatore"). Al contrario la presente garanzia avrà dodici (12) mesi di durata dalla data di acquisto del Prodotto (data documento fiscale rilasciato all'atto dell'acquisto) qualora il Prodotto al quale si riferisce sia acquistato per fini inerenti alla propria attività imprenditoriale, commerciale e professionale. I termini di garanzia di cui sopra sono validi a condizione che i Prodotti siano messi in funzione entro i 3 mesi dalla data di uscita dagli stabilimenti di **A2B ACCORRONI E.G.**;
- Per i Prodotti per i quali è previsto l'obbligatorietà della prima accensione, pena la decadenza della garanzia, questa decorrerà dall'avviamento degli stessi Prodotti da dimostrarsi mediante idonea documentazione e purché ciò avvenga entro 6 mesi dall'uscita del magazzino di **A2B ACCORRONI E.G.** del medesimo Prodotto. I Prodotti per i quali è prevista la prima accensione obbligatoria sono quelli appartenenti alla categoria **Energie Rinnovabili, Climatizzazione** nel catalogo commerciale o nel listino;
- L'Acquirente del Prodotto deve rivolgersi al rivenditore, ossia al soggetto con il quale ha finalizzato il contratto di acquisto del Prodotto, per qualsiasi richiesta inerente la garanzia sullo stesso.

## 1) EFFICACIA E OPERATIVITÀ

- La presente garanzia è operativa ed efficace alla condizione che siano osservate le istruzioni e le avvertenze per la corretta installazione, la conduzione, l'uso e la manutenzione che accompagnano il Prodotto e nel rispetto delle leggi in vigore. Conferimento a ciò, il Prodotto deve essere installato e regolato da personale qualificato nel rispetto di leggi e regolamenti in vigore (UNI-EN, UNICIG, VV.FF, CEI...\*). Inoltre deve essere montato solamente su impianti realizzati da personale munito di PEF/F-Gas (Patentino Europeo Frigoristi) come da DPR 43/2012. Si precisa che comunque l'installatore resta il solo responsabile dell'installazione.

- La presente garanzia è fornita esclusivamente tramite i centri assistenza (CAT) da **A2B ACCORRONI E.G.**;
- L'Acquirente del Prodotto deve conservare ed esibire il documento fiscale rilasciato all'atto dell'acquisto per poter usufruire della garanzia con le durate sopra descritte e relative uscite senza addebito da parte dei Cat. In caso contrario verrà preso come termine di decorrenza la data del Ddt di uscita del Prodotto dagli stabilimenti di **A2B ACCORRONI E.G.**;
- La garanzia e gli interventi che si svolgeranno all'interno dei periodi descritti sopra in conformità alle normative precedentemente citate, incluso il primo avviamento per i Prodotti che lo richiedono, riguarderanno esclusivamente il Prodotto in sé, non si estenderanno all'impianto e non potranno essere assimilati in alcun modo a collaudi e/o verifiche dello stesso che sono riservati per legge a installatori e manutentori abilitati e comunque a carico e sotto la responsabilità dell'Acquirente del Prodotto e degli stessi. Nessun intervento, dall'avviamento all'intervento in garanzia e fuori garanzia, solleva il proprietario dell'impianto dal rispetto e dalle verifiche necessarie secondo normative o si sostituisce allo stesso. Quest'ultimo inoltre, a proprie spese, è responsabile nel garantire ai Cat le condizioni di operatività in sicurezza per ogni intervento come da D. Lgs 81/08, nonché il rispetto della manutenzione ordinaria da effettuarsi come da manuale allegato al Prodotto.

## 2) ESCLUSIONI

Dalla presente garanzia vengono esclusi i Prodotti o i casi riguardanti gli stessi che presentano anche solo una delle seguenti caratteristiche:

- mancanza di gas refrigerante e quindi necessità di ricarica;
- i Prodotti con matricola o etichetta dell'unità e/o della documentazione accompagnatoria illeggibili, mancanti o alterate;
- i Prodotti che non abbiano rispettato anche solo in parte le istruzioni di installazione, conduzione, uso e manutenzioni contenute nel manuale accompagnatorio del Prodotto;
- i Prodotti installati senza la presenza di una protezione elettrica adeguata e del collegamento con massa a terra;
- i Prodotti installati da personale non qualificato secondo quanto richiesto dalle normative vigenti, sprovvisti di Pef e abilitazioni, collegati a impianti elettrici /Idraulici/ del gas sprovvisti della documentazione necessaria per legge (conformità, certificazione degli impianti, libretto...\*);
- i Prodotti che riportano un incremento di danni derivati dall'ulteriore utilizzo degli stessi da parte dell'acquirente una volta manifestato il malfunzionamento e/o nel tentativo di porre rimedio a quanto rilevato inizialmente;
- gli interventi da effettuarsi con autoscalo, ponteggi, trabattelli, sistemi di elevazione o di sollevamento e/o di trasposto; i costi per interventi che richiedano misure di sicurezza non presenti già nella configurazione installativa\*. Questi costi rimangono a carico dell'Acquirente: si ricorda che i centri assistenza (CAT) sono autorizzati ad intervenire solo nei casi in cui i Prodotti siano installati ad altezza non superiore ai 2 mt da un piano lavorativo stabile sul quale si possa operare a norma del D. Lgs 81/08. In tutti gli altri casi sarà cura e responsabilità dell'Acquirente/Consumatore disporre le attrezzature necessarie e sostenere i costi per la messa in sicurezza dei tecnici durante l'intervento;

- le eventuali avarie di trasporto (graffi, ammaccature e simil\*);
- i danni da usura, degrado, mancato utilizzo, errata installazione, rotture accidentali, sbalzi di tensione elettrica\*;
- le anomalie o il difettoso funzionamento dell'alimentazione elettrica, idraulica, del gas, dei camini o delle canne fumarie (qualora richieste dal Prodotto)\*;
- i danni e le avarie causate da trascuratezza, negligenza, manomissione, mancata regolare manutenzione (pulizia filtri aria, pulizia batterie evaporanti, pulizia batterie condensanti, pulizia fori di scarico condensa, serraggio dei morsetti elettrici, disassemblaggio, incapacità d'uso, riparazione effettuate da personale non autorizzato\*, e tutto quanto previsto dal manuale di uso del Prodotto);
- i Prodotti che presentano occlusioni delle tubazioni, interne ed esterne anche sottraccia, del circuito frigorifero dovute alla mancanza di pulizia e/o al mancato corretto svolgimento dell'operazione di vuoto all'impianto;
- le guarnizioni in gomma e componenti in gomma, materiali di consumo quali olio, filtri, refrigeranti, le parti in plastica, mobili o asportabili\*;
- la rottura o il malfunzionamento del telecomando.
- i Prodotti dove si rileva l'utilizzo di ricambi non originali e/o non adeguati;
- i Prodotti sui quali è stato eseguito il primo avviamento (ove richiesto) o la manutenzione da personale diverso dai Cat **A2B ACCORRONI E.G.**;
- i Prodotti non avviati entro 3 mesi dal Ddt di uscita dagli stabilimenti di **A2B ACCORRONI E.G.**. In questo caso è a carico dell'acquirente dimostrare che quanto rilevato rientra in garanzia;
- i danni causati dalla mancata adozione degli ordinari accorgimenti per mantenere il Prodotto in buono stato: non evitando surriscaldamento, corrosioni, incrostazioni, rotture provocate da corrente vagante, condense, aggressività o acidità dell'acqua, trattamenti disincrostanti impropri, mancanza di acqua, depositi di fanghi o di calcare, mancanza di alimentazione elettrica o di gas\*;
- i danni provocati dal posizionamento del Prodotto in ambienti umidi, polverosi o comunque non idonei alla sua corretta operatività;
- i danni provocati da uno stoccaggio del Prodotto in ambienti inadatti alla sua corretta conservazione prima dell'installazione;
- i danni provocati dall'inefficienza/inadeguatezza di strutture o impianti (elettrico, idraulico\*) collegati al Prodotto;
- i danni provocati dall'errato dimensionamento del Prodotto in base al suo uso;
- i danni provocati da atti dolosi, di forza maggiore (eventi atmosferici, incendio, fulmini, interferenze elettriche, ossidazione, ruggine, terremoti, furto)\* e/o casi fortuiti;
- i danni derivati dal mancato contenimento dell'inquinamento atmosferico ed acustico fatti salvi i limiti normativi in essere;
- Tutto quanto elencato in questo punto determina che l'intervento è completamente a carico dell'Acquirente/Consumatore che dovrà corrispondere al centro assistenza (CAT) intervenuto i costi per l'uscita a domicilio, di verifica e di trasporto, il materiale utilizzato, la manodopera\*, sia che la fornitura sia avvenuta direttamente tramite **A2B ACCORRONI E.G.** o tramite altro soggetto che commercializza il Prodotto;

\* Questi elenchi di situazioni sono a titolo esemplificativo ma non esaustivo

## 3) TIPOLOGIE, MODALITÀ E TEMPISTICHE DI INTERVENTO

- Al fine di segnalare il presunto difetto di conformità del Prodotto, quale condizione necessaria per l'attivazione della garanzia, l'Acquirente/Consumatore del Prodotto, tramite il rivenditore, ossia il soggetto con il quale ha finalizzato il contratto di acquisto del Prodotto, dovrà contattare l'ufficio post-vendita di **A2B ACCORRONI E.G.**;
- Al momento della segnalazione dovranno essere forniti i dati identificativi ed i contatti dell'Utente finale, oltre al codice identificativo del Prodotto in questione (modello e n° matricola). Tali indicazioni saranno necessarie per consentire ad **A2B ACCORRONI E.G.** di accertare la data di uscita del medesimo Prodotto dai propri magazzini, in mancanza del codice identificativo, la garanzia non potrà trovare applicazione.
- Ricevuta la segnalazione **A2B ACCORRONI E.G.** provvederà ad informare i propri centri assistenza autorizzati (CAT) competenti per area territoriale e per tipologia di Prodotto. Il CAT fisserà con l'utente finale un appuntamento per effettuare un sopralluogo sul Prodotto in questione mediante un proprio incaricato.
- Qualora durante tale sopralluogo il centro assistenza (CAT) dovesse riscontrare un difetto di conformità del Prodotto lo stesso centro assistenza (CAT) si attiverà per effettuare la necessaria riparazione. **A2B ACCORRONI E.G.** di riserva di decidere l'eventuale sostituzione del Prodotto o di parte dello stesso nel caso in cui, a suo insindacabile giudizio, la riparazione non sia economicamente conveniente. Riparazione o sostituzione non comporteranno costi aggiuntivi per l'Utente finale o per il rivenditore da cui lo stesso Utente finale abbia acquistato il medesimo Prodotto. Il tal caso anche le spese del predetto sopralluogo non saranno addebitate.
- L'Acquirente/Consumatore deve segnalare il malfunzionamento e/o difettosità nel periodo vigente di garanzia e comunque entro e non oltre i due mesi dalla scoperta del difetto o dell'avaria.
- gli interventi effettuati dai centri assistenza (CAT), durante il normale orario lavorativo, eventuali ritiri e verifiche del Prodotto, riparazioni e sostituzioni, avverranno in un congruo termine temporale compatibile con le esigenze organizzative e produttive di **A2B ACCORRONI E.G.**;
- eventuali interventi, riparazioni o sostituzioni del Prodotto non daranno comunque luogo a prolungamenti o a rinnovi della garanzia né alla modifica della sua scadenza originale. Le parti sostituite in garanzia rimarranno di proprietà di **A2B ACCORRONI E.G.**;
- nella sostituzione di parte del Prodotto o del Prodotto completo potranno essere impiegati parti o Prodotti identici o con pari caratteristiche.

Le procedure di assistenza precedentemente descritte potranno subire variazioni e/o aggiornamenti da parte di **A2B ACCORRONI E.G.** Si precisa che tutto quanto sopra descritto non si estende mai all'obbligo di risarcimento danni e rimborsi spese o costi di qualsiasi natura subiti da persone o cose, e che nessuno, tranne che **A2B ACCORRONI E.G.**, è autorizzato a modificare i termini sopra né a rilasciarne altri sia verbali che scritti. Per qualsiasi controversia il foro competente è il Tribunale di **Ancona**.



# DICHIARAZIONE DI CONFORMITÀ DECLARATION OF CONFORMITY

**Fornitore Supplier:** A2B Accorroni E.G. srl

**Indirizzo Address:** 60027 Osimo (AN) – Via D’Ancona,37 Tel. 071/723991

**Apparecchi Appliances:** Hub Radiator Mini, Hub Radiator Plus, Hub Radiator Plus Solar, Hub Radiator AP, Super Hub Radiator, Hub Radiator Black

Con riferimento agli apparecchi in oggetto nelle versioni di serie per la pompa di calore con serbatoio ad accumulo integrato, la A2B Accorroni E.G. srl;

With reference to the appliances in question in the standard versions for the heat pump with integrated storage tank, the A2B Accorroni E.G. srl;

## DICHIARACHE i prodotti di cui sopra - DECLARES that the above products

MEETS THE REQUIREMENTS OF DIRECTIVE 2006/42/CE  
SONO CONFORMI AI REQUISITI DELLA DIRETTIVA 2006/42/CE

1. The unit is in CAT. I, so it's free from the application of Directive 2014/68/UE (Reference to Art. I, paragraph 2, point f) L'attrezzatura a pressione rientra nella CAT. I. L'unità è quindi esente dall'applicazione della normativa PED 2014/68/UE (Riferimento Art. I, paragrafo 2 punto f).
2. Harmonized standards applied to designing and manufacture : UNI EN 378 - 1, UNI EN378 - 2, UNI EN 12735 - 1  
Norme armonizzate applicate alla progettazione ed alla costruzione : UNI EN 378 - 1, UNI EN378 - 2, UNI EN 12735 - 1
3. Others European Directives and harmonized standards applied to the equipment: 2014/35/UE, 2014/30/UE, 2011/65/UE, 2012/19/UE, CEI EN 60335 - 2 - 40, CEI EN 55014 - 1, CEI EN 55014 - 2, CEI EN 61000 - 3 - 2, CEI EN 61000 - 3 - 3, CEI EN 62233  
Eventuali altre Direttive Europee e norme armonizzate applicate all'attrezzatura: 2014/35/UE, 2014/30/UE, 2011/65/UE, 2012/19/UE, CEI EN 60335 - 2 - 40, CEI EN 55014 - 1, CEI EN 55014 - 2, CEI EN 61000 - 3 - 2, CEI EN 61000 - 3 - 3, CEI EN 62233

e conformi alla direttiva CE sui prodotti da costruzione e rispettano i requisiti della seguente direttiva:  
and comply with the EC Construction Products Directive and meet the requirements of the following directive:

- 89/106 / EEC Construction Products Directive, Appendix III - 2 - ii - 3 In accordance with
- En12897 Storage water heater (reference for the type of construction only partially applicable)
- 89/106/CEE Direttiva sui prodotti da costruzione, appendice III – 2 – ii – 3 In conformità a
- En12897 Scaldacqua ad accumulo (riferimento per il tipo di costruzione applicabile solo in parte)

Osimo, Maggio 2021



A2B Accorroni E.G. srl

Il legale Rappresentante

The legal representative

*A. Tamura Lorenza*



A2B Accorroni E.G. s.r.l.  
Via d'Ancona, 37 - 60027 Osimo (An) - Tel. 071.723991  
web site: [www.accorroni.it](http://www.accorroni.it) - e-mail: [a2b@accorroni.it](mailto:a2b@accorroni.it)