

# COND SYSTEM

Condensation boiler outdoor / indoor combined with indoor heaters



**CSN 35 E**

Heating only for outdoor installation  
with standard remote control



Air heater Aeroclima **STYLE 10 - 15** hot/cold



**M 50**

With stainless steel frame  
for outdoor installation





**M 75 - M 100**

For outdoor installation  
remote control as standard



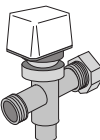

Model	Thermal kW	Code	€
<b>Boiler CSN 35 E + n. 1 Aeroclimate STYLE 15 (heat only)</b>	<b>32,0</b>	<b>30415002</b>	<b>4.900,00</b>
<b>Boiler CSN 35 E + n. 2 Aeroclimate STYLE 10 (heat only)</b>	<b>32,0</b>	<b>30405002</b>	<b>6.160,00</b>
<b>M50 boiler for outdoor + n. 1 Aeroclimate STYLE 15 (heat only)</b>	<b>51,0</b>	<b>30405004</b>	<b>8.400,00</b>
<b>M75 boiler for outdoor + n. 2 Aeroclimate STYLE 15 (heat only)</b>	<b>75,8</b>	<b>30405005</b>	<b>12.023,00</b>
<b>M100 boiler for outdoor + n. 2 Aeroclimate STYLE 15 (heat only)</b>	<b>97,1</b>	<b>30405006</b>	<b>13.050,00</b>

# COND SYSTEM

Condensation boiler outdoor / indoor combined with indoor heaters

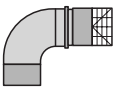

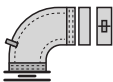





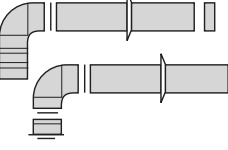
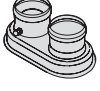
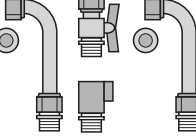

Accessories Aeroclima STYLE 10 - 15		Code	€
	Wall-mounted electronic thermostat (with valve control complete with 4m cable)	36205221	82,00
	Mechanical consent thermostat for wall-mounted electronic thermostat	36205214	36,00
	Basic command with summer / winter switch and manual selector of the 3 speeds	36205217	58,00
	3-way valve with ON / OFF actuator complete with installation kit	36205404	180,00

## Accessories for boilers CSN 35 E

	Coaxial curve kit Ø 60/100 with terminal	<b>Included in the price</b>	
	<b>CONTAINMENT CONTAINER WALL INSTALLATION</b> for the recessed solution, made of galvanized sheet, with bracket for positioning the thermal generator and preparing holes for flue gas discharge and combustion air passage, both on the upper side that the lateral ones complete with closing panel	30403020	170,00
	Flue outlet kit Ø 60/100 coaxial	30403000	130,00
	Coaxial 90° curve Ø 60/100 with flange and analysis	30403005	46,00
	Curve 90° Ø 60/100 coaxial M / F	30403004	40,00
	Curve 90° Ø 80 M / F	30403013	24,00

# COND SYSTEM

Condensation boiler outdoor / indoor combined with indoor heaters

Accessories for boilers CSN 35		Code	€
	Coaxial extension Ø 60/100 M / F = 1000 mm	30403002	44,00
	Extension Ø 80 M / F = 1000 mm mm	30403011	32,00
	Smoke exhaust kit with coaxial roof Ø 60/100	30403014	170,00
	Split flue gas exhaust kit Ø 80/80	30403007	160,00
	Splitter kit Ø 80/80	30403018	70,00
	Installation kit	30404000	50,00
	Flange connection with analysis sockets Ø 60/100 (to be coupled to the exhaust kit)	30403015	46,00
	External probe	30402003	64,00
	Tube M / M Ø 60 X 1.5 = 50 mm	30403016	12,00
	Suction terminal Ø 80 horizontal	30403017	20,00
	45° coaxial curve M / F Ø 60/100	30403003	62,00
	45° curve Ø 80 M / F	30403012	42,00
	Ø 80 vertical smoke outlet terminal	30403019	60,00

# COND SYSTEM

Condensation boiler outdoor / indoor combined with indoor heaters

## Accessories for boilers 50 M - 75 M - 100 M

Code €



Remote chrono thermostat for M 50 boiler

30402006 165,00

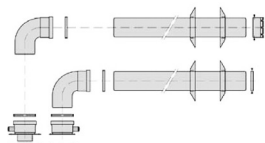

### KIT Ø 80

Air intake pipes and double exhaust fumes Ø 80 mm consisting of:

- n. 2 vertical flanged air / fume connections in PP.
- n. 2 multi-directional PP Ø80 90 ° curves M.F. with connections for air / smoke extraction
- n. 2 terminals in PP Ø 80 from m 1 (external air intake and wall exhaust fumes)
- n. 4 EPDM Ø 80 cover plates

30403088 170,00

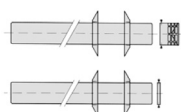

### KIT Ø 60

Air intake pipes and double fume exhaust Ø 60 mm consisting of n. 2 terminals in PP Ø 60 from 1 m with cover plates

**Aspiration**

30403089 40,00

**Expulsion**

30403090 52,00



Flanged suction and discharge nozzles in PP Ø 80

30403091 52,00



“T” fitting kit (M-M-F) Ø 60 in PP with condensation drainage cap Ø 60 in PP

30403092 52,00



Reduction (M-F) Ø 80 - Ø 60 in PP

30403093 26,00

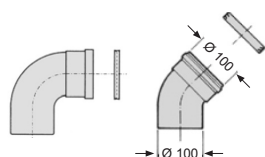

Curve (M-F) Ø 100

**Curva in PP Ø 100 M F a 90°**

30403104 34,00

**Curva in PP Ø 100 M F a 45°**

30403105 26,00



Kit raccordo a “T” (M-M-F) Ø 100 in PP con tappo raccogli condensa Ø 100 in PP

30403106 106,00

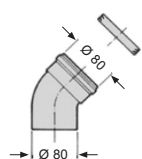

Curve 45°

**Curve in PP Ø 80 M F at 45°**

30403101 26,00

**Curve in PP Ø 60 M F at 45°**

30403102 26,00



Extension M F in PP Ø 100 of 1 meter

30403103 66,00

# COND SYSTEM

Condensation boiler outdoor / indoor combined with indoor heaters

## Accessories for boilers 50 M - 75 M - 100 M

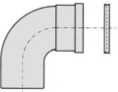
		Code	€
	Extension	PP extension Ø 80 mm 0,5	30403094 40,00
		PP extension Ø 80 m 1	30403095 40,00
		PP extension Ø 80 m 2	30403096 80,00
		PP extension Ø 60 m 1	30403097 40,00
		PP extension Ø 60 m 2	30403098 52,00
	Curve 90°	Curve in PP Ø 80 M F at 90°	30403199 26,00
		Curve in PP Ø 60 M F at 90°	30403100 26,00

## Dimensions of the boiler 50 M

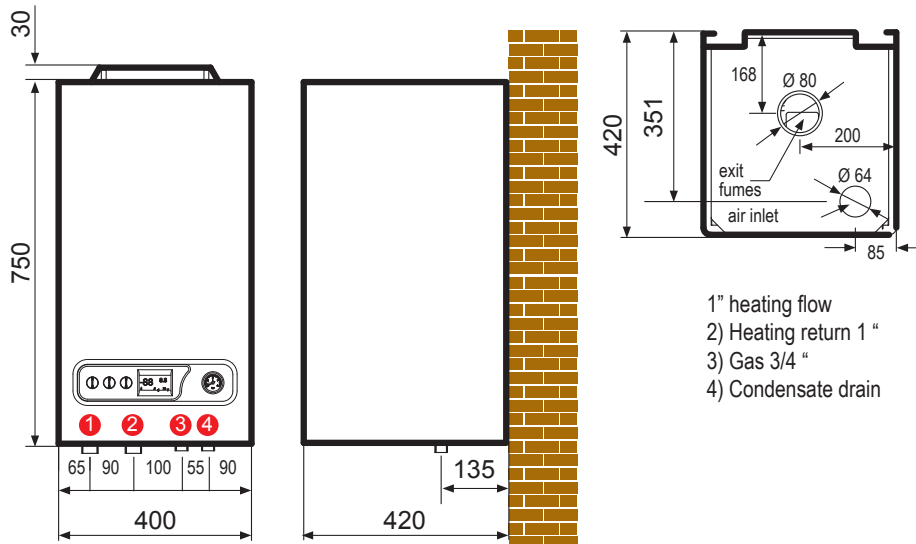

## Boiler size 75 M - 100 M

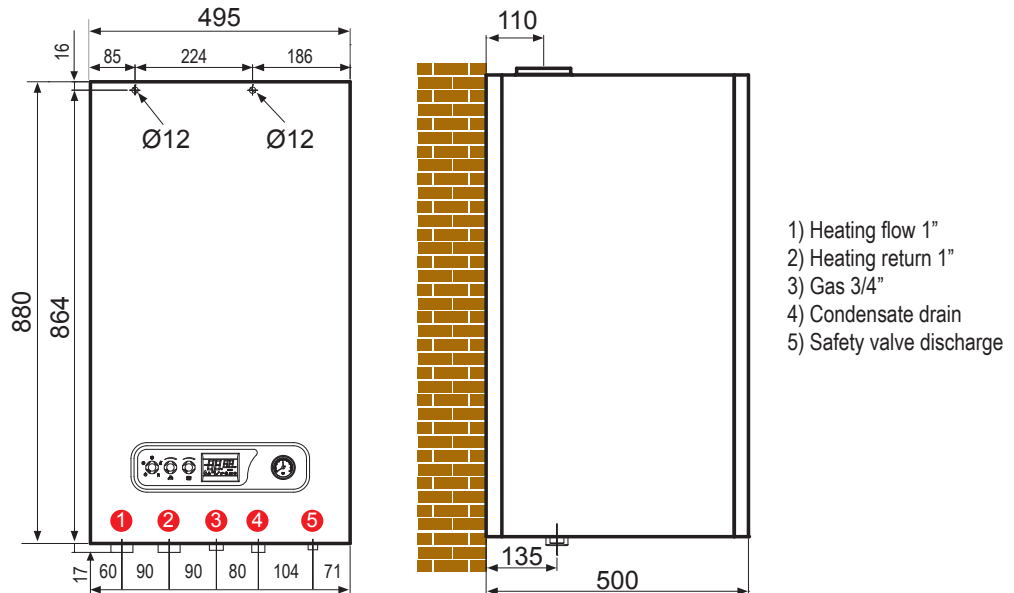

# COND SYSTEM

Condensation boiler outdoor / indoor combined with indoor heaters

## CSN 35 E boiler dimensions

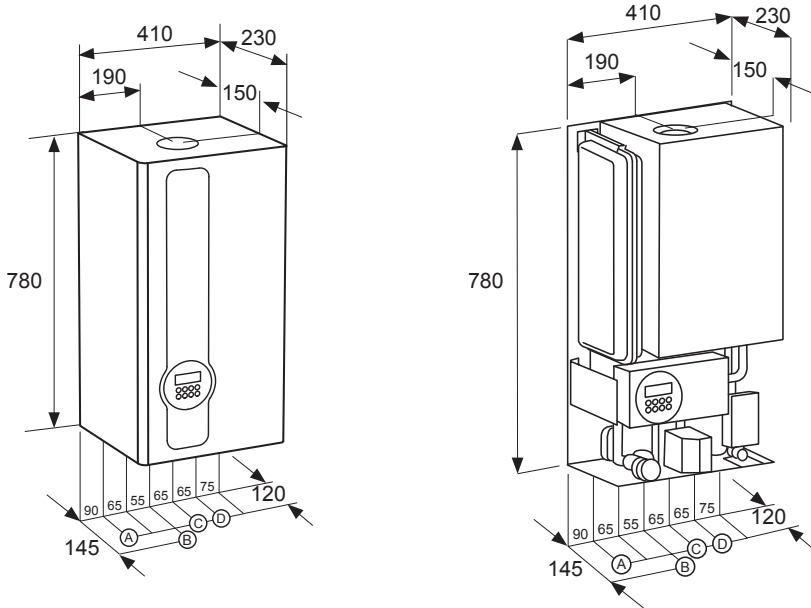

- A - 3/4" system delivery
- B - 3/4" gas
- C - 1/2" cold water inlet
- D - 3/4" system return

## Aeroclimate size STYLE 10

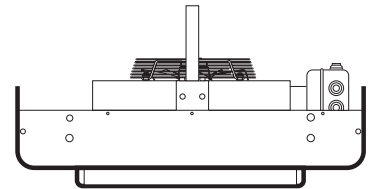
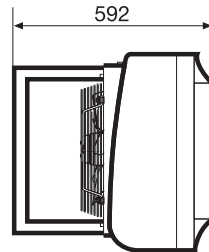
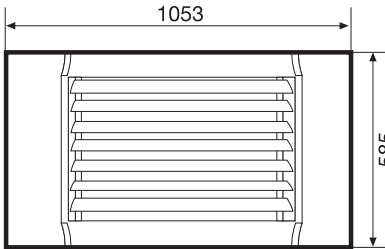

## Aeroclimate size STYLE 15

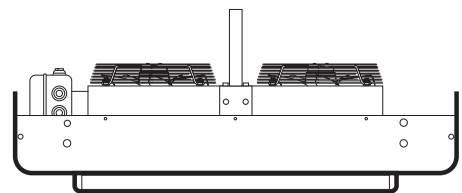
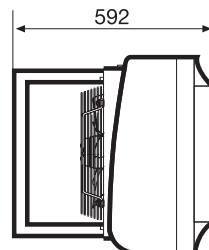
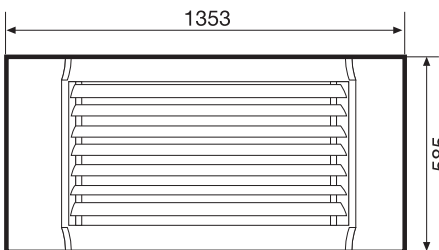

# COND SYSTEM

Condensation boiler outdoor / indoor combined with indoor heaters

## Example of installation COND SYSTEM

Example of **COND SYSTEM** installation which includes the condensing boiler **CSN 35 E** with the combination of 1 air heater **Aeroclimate STYLE 15** for space heating.

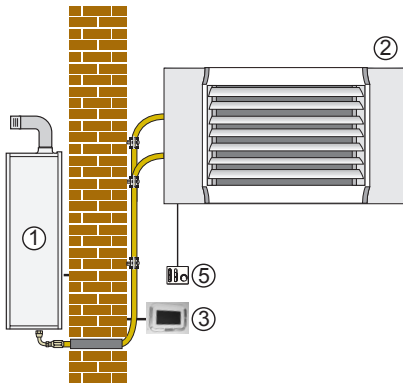

1 Boiler CSN 35 E - 2 Air heater Aeroclima STYLE 15 - 3 Remote control - 4 Electronic thermostat - 5 Basic control

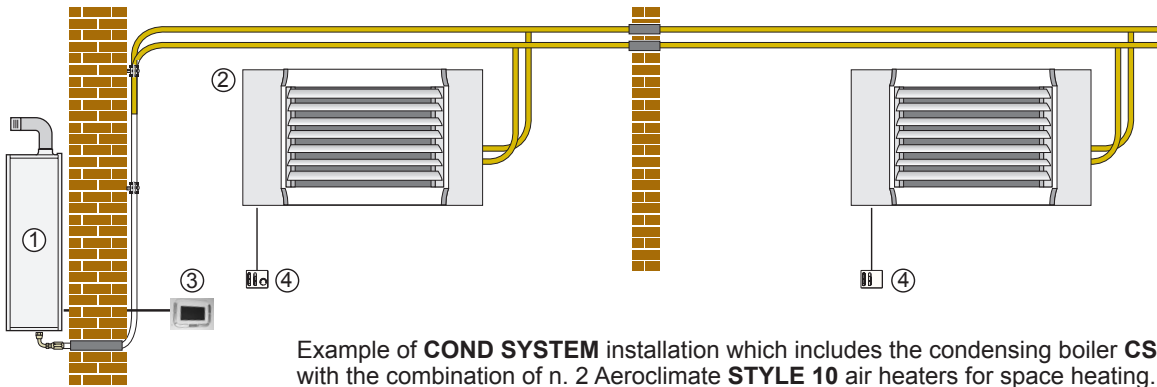

Example of **COND SYSTEM** installation which includes the condensing boiler **CSN 35 E** with the combination of n. 2 Aeroclimate **STYLE 10** air heaters for space heating.

## Possible directions of the fins

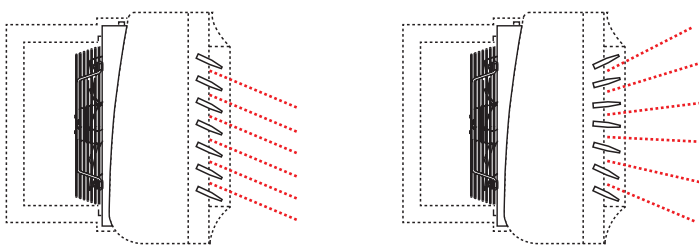

## Incorrect airflow



## Installation height

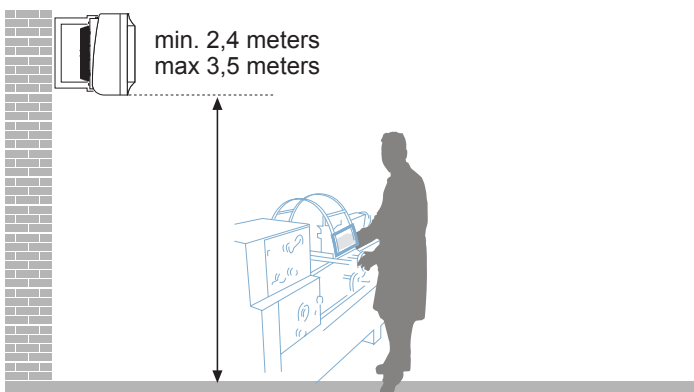

## Optimal airflow

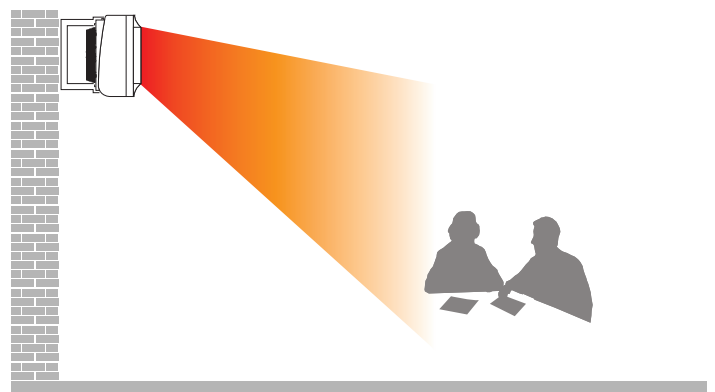

# COND SYSTEM

Condensation boiler outdoor / indoor combined with indoor heaters

## Technical data boiler CSN 35 E

DESCRIPTION	U.M.	CSN 35 E
Category		II2E+3P - II2H2P - II2E3P - I2HI3PI2L
Type		C13 - C53
Reference gas		G20-G25-G31
Energy Performance		☆☆☆☆
Nominal thermal flow	kW	32,0
Minimum thermal flow	kW	3,2
<b>HEATING</b>	°C	80 / 60
Nominal thermal power	kW	29,1
Minimum thermal power	kW	2,9
Burning efficiency	%	97,4
Partial load performance at 30%	%	105,4
GAS G20 gas supply pressure	mbar	20
GAS G25 gas supply pressure	mbar	25
GAS G31 gas supply pressure	mbar	37
Mass flow rate of flue gas at nominal flow / min G20	kg/h	47 / 10
Mass flow rate of flue gas at nominal flow / min G25	kg/h	47 / 10
Mass flow rate of flue gas at nominal flow / min G31	kg/h	48 / 10
CO <sub>2</sub> with thermal flow rate nom./min G20	%	9,4 / 9,0
CO <sub>2</sub> with thermal flow rate nom./min G25	%	9,4 / 9,0
CO <sub>2</sub> with thermal flow rate nom./min G31	%	10,6 / 10,1
CO at 0% of O <sub>2</sub> at nominal flow / min G20	ppm	168 / 4
CO at 0% of O <sub>2</sub> at nominal flow / min G25	ppm	167 / 4
CO at 0% of O <sub>2</sub> at nominal flow / min G31	ppm	188 / 3
NO <sub>x</sub> a 0% di O <sub>2</sub> a portata termica nom./min G20	ppm	45 / 17
NO <sub>x</sub> a 0% di O <sub>2</sub> a portata termica nom./min G25	ppm	44 / 18
NO <sub>x</sub> a 0% di O <sub>2</sub> a portata termica nom./min G31	ppm	49 / 21
Flue gas temperature at nominal flow / min (80/60 °C) G20	°C	68 / 66
Flue gas temperature at nominal flow / min (80/60 °C) G25	°C	68 / 66
Flue gas temperature at nominal flow / min (80/60 °C) G31	°C	70 / 68
NO <sub>x</sub> Class		5
Expansion vessel	l	7
Preload expansion vessel	bar	1
Max working pressure	bar	3
Min working pressure	bar	0,6
Max working temperature	°C	90
<b>ELECTRICAL CHARACTERISTICS</b>		
Power supply		230V/1/50Hz
Absorbed power	W	180
Degree of protection		IP X4D
<b>DIMENSIONS AND CONNECTIONS</b>		
Width	mm	410
Height	mm	780
Depth	mm	230
Weight	kg	40
Supply / return		3/4"
Gas		3/4"
Concentric exhaust / outlet diameter	mm	60 / 100
Concentric tube length min / max	m	(0,5÷10) + (1 curva a 90°)
Separate suction / discharge pipe diameter	mm	80 / 80
Separate pipe length min / max	m	(0,5÷32) + (0,5÷32) + (2 curve a 90°)



# COND SYSTEM

Condensation boiler outdoor / indoor combined with indoor heaters

## Technical data boiler 50 M - 75 M - 100 M

DESCRIPTION	U.M.	50 M	75 M	100 M
Reference gas			G20	
Nominal thermal flow	kW	48,0	70,0	90,0
Nominal heat output / return flow temperature 80/60 ° C	kW	47,2	67,9	87,6
Nominal heat output / return temperature 50/30 ° C	kW	51,0	75,8	97,1
Energetic class		A		
Minimum thermal flow	kW	9,0	14,0	18,0
Minimum thermal power	kW	8,8	13,4	17,1
Max working pressure of the boiler	bar	3,5	6,0	6,0
Number of revolutions max	rpm	5600	5500	5500
Number of revolutions min	rpm	1200	1300	1300
Exhaust gas flow P max	Kg/h	80,5	117,5	151,0
Exhaust gas flow P min	Kg/h	16,1	24,3	31,2
Degree of protection		IPX5D	IPX4D	IPX4D
Power supply		230V/1/50Hz		
Temperature of fumes	°C	70		
CO <sub>2</sub> at nominal power	%	9,0		
CO <sub>2</sub> at minimum power	%	8,7		
Total boiler capacity	l	5	6	8
Empty weight	Kg	60	65	75

# COND SYSTEM

Condensation boiler outdoor / indoor combined with indoor heaters

**Tabella dati tecnici Aeroclima STYLE 10-15**

DESCRIPTION	U.M.	STYLE 10	STYLE 15
Combined machines	n.	2	1
Thermal power (1)	max	kW	14,9
	med	kW	13,8
	min	kW	11,9
Water flow ( $\Delta T$ 20 ° C)	l/h	645	1290
Losses of load	kPa	4,0	6,0
Hydraulic circuit volume	dm <sup>3</sup>	4,0	6,0
Air side heat jump	min	°C	20,3
	max	°C	21,8
Total cooling caacity (4)	max	kW	10,2
	med	kW	9,6
Water intake 7 ° C ( $\Delta T$ 5 ° C)	min	kW	8,5
	max	kW	8,4
Sensitive cooling power (3)	med	kW	7,8
	min	kW	6,7
Water intake 7 ° C ( $\Delta T$ 5 ° C)			9,2
Water flow	l/h	1754	2993
Losses of load	kPa	9,2	11,4
Hydraulic circuit volume	l	4	6
	max	m <sup>3</sup> /h	2180
Air flow	med	m <sup>3</sup> /h	1980
	min	m <sup>3</sup> /h	1620
Auxiliary speeds (2)	n. (m <sup>3</sup> /h)	15 (450÷2200)	15 (1080÷4600)
Number of fans	n.	1	2
Sound pressure (5 m free field with directionality factor 2)	max	dB(A)	49,5
	med	dB(A)	47,8
	min	dB(A)	45,6
Sound power	max	dB(A)	71,5
	med	dB(A)	69,8
	min	dB(A)	67,6
Sound pressure speed aux (3)	dB(A)	32,0÷56,3	34,8÷65,3
Power supply		230V/1/50Hz	
Launch speed max	m	20	22
Min. Speed launch	m	14	15
Electric power absorbed	max	W	115
	med	W	105
	min	W	85
Max absorbed current	A	0,63	1,20
Degree of protection of the fan (s)			IP 44
Degree of protection of the appliance			IP 24
Operating limits			
Water temperature min. To max	°C	3÷80	
Max pressure	kPa	800	
Input air temperature max	°C	45	
Weight	kg	44	59

1 Water inlet 50 °C -  $\Delta T$  5 °C

2 Ventilation speeds selectable in addition to the standard ones

3 Sound pressure level at 1 meter, in free field with directionality factor 2, in the minimum and maximum value of the auxiliary speeds available

4 Air temperature b.d. 27 °C, b.h. 19 °C - 47% U.R.